

Nokia Customer Care

Service Manual

**RM-409; RM-417 (Nokia 5320 XpressMusic;
L3&4)**

Schematics

Part No: (Issue 3)

COMPANY CONFIDENTIAL



BLUETOOTH & FM RADIO DISCRETE

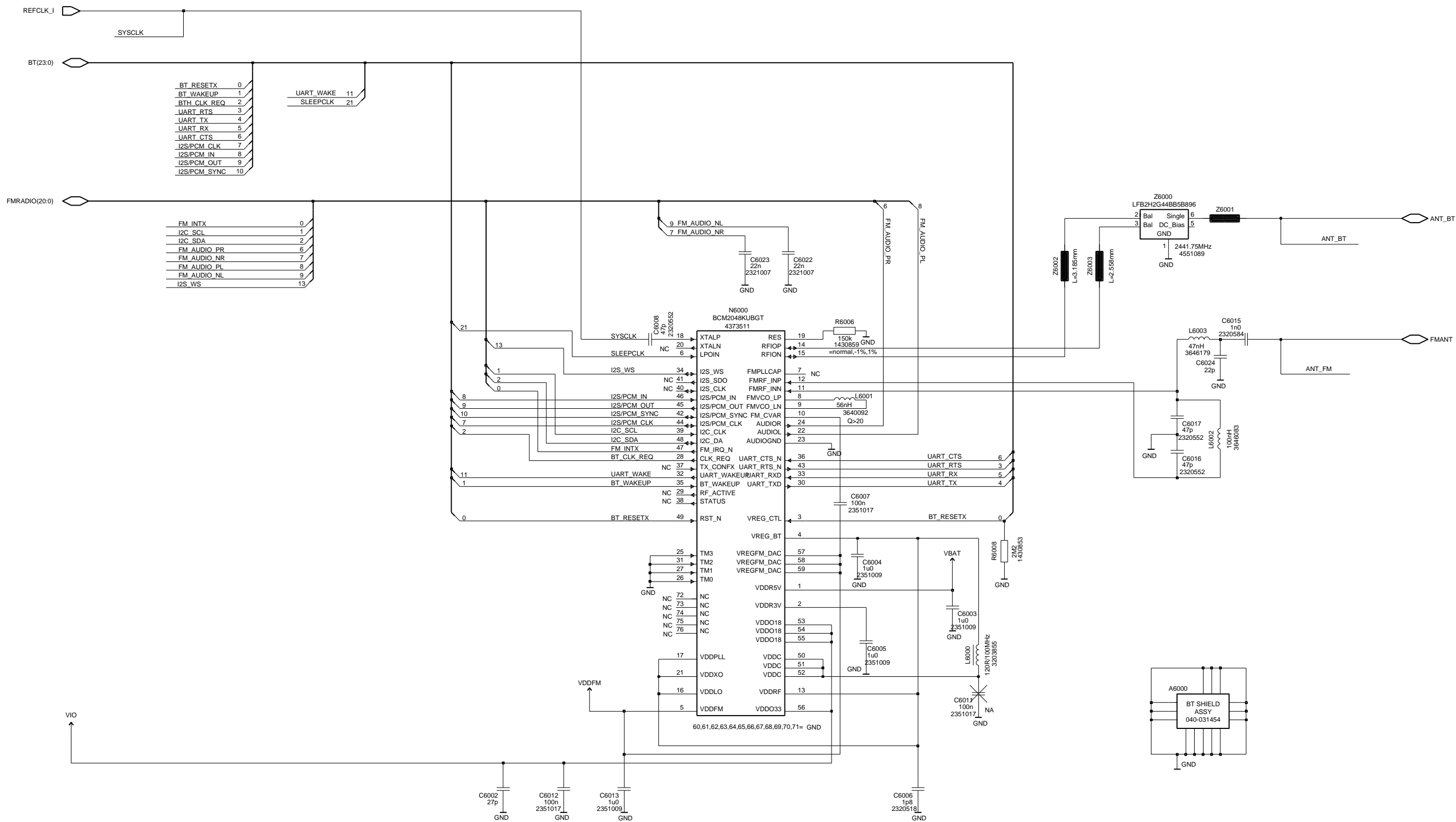

Notes.

- 1) 3k3 Pull-up Resistors are required on I2C_SCL & I2C_SDA
- 2) Additional test components for phone wing boards are given in BTHfmrds2.0_Test Schematic
- 3) E6033 will be used in future release for 1.8V operation.

<p>Copyright (C) Nokia Corporation. All rights reserved. THIS DRAWING IS PROTECTED BY COPYRIGHT AS AN UNPUBLISHED WORK. UNAUTHORIZED REPRODUCTION OF THIS DRAWING IS NOT PERMITTED. THIS DRAWING CONTAINS PROPRIETARY AND CONFIDENTIAL INFORMATION. This document is property of Nokia Corporation</p>		<table border="1" style="width: 100%; border-collapse: collapse;"> <tr> <td>Name</td> <td>BTFM RDS 2.0D (2+4+2)</td> <td>Appr</td> <td>dd-mmm-yy</td> </tr> <tr> <td>Assoc</td> <td></td> <td>Des.</td> <td>06-Sep-06</td> </tr> <tr> <td></td> <td></td> <td>Dr.</td> <td>26-Feb-08</td> </tr> <tr> <td>File</td> <td></td> <td>Sheet</td> <td>1 of 1 0 (01)</td> </tr> <tr> <td>Proj</td> <td></td> <td>Print</td> <td>Yes V. 0.0 Edit 20</td> </tr> </table>	Name	BTFM RDS 2.0D (2+4+2)	Appr	dd-mmm-yy	Assoc		Des.	06-Sep-06			Dr.	26-Feb-08	File		Sheet	1 of 1 0 (01)	Proj		Print	Yes V. 0.0 Edit 20	
Name	BTFM RDS 2.0D (2+4+2)	Appr	dd-mmm-yy																				
Assoc		Des.	06-Sep-06																				
		Dr.	26-Feb-08																				
File		Sheet	1 of 1 0 (01)																				
Proj		Print	Yes V. 0.0 Edit 20																				

VDAC reg

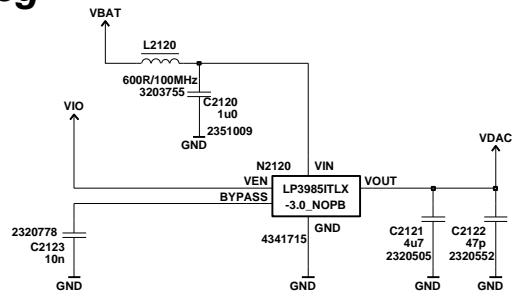

DAC33

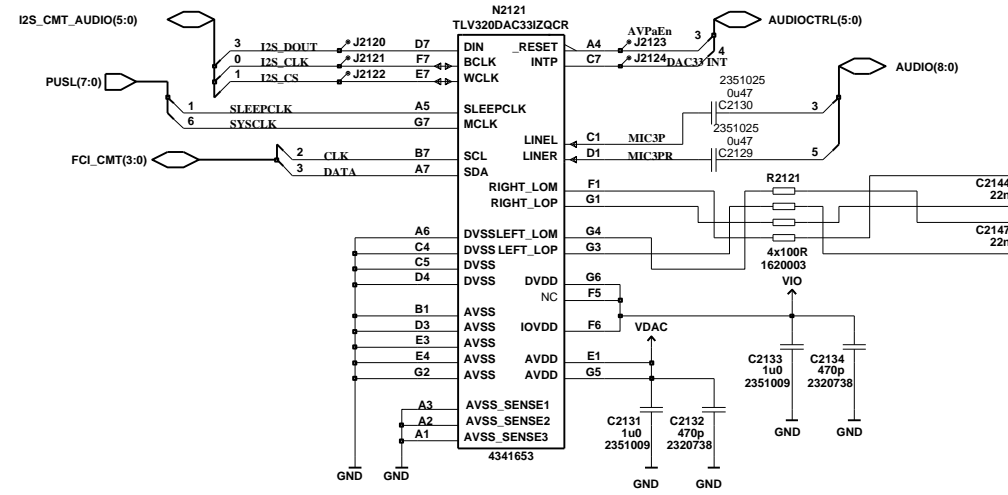

REF 2120-2149 DAC33 + TPA6130

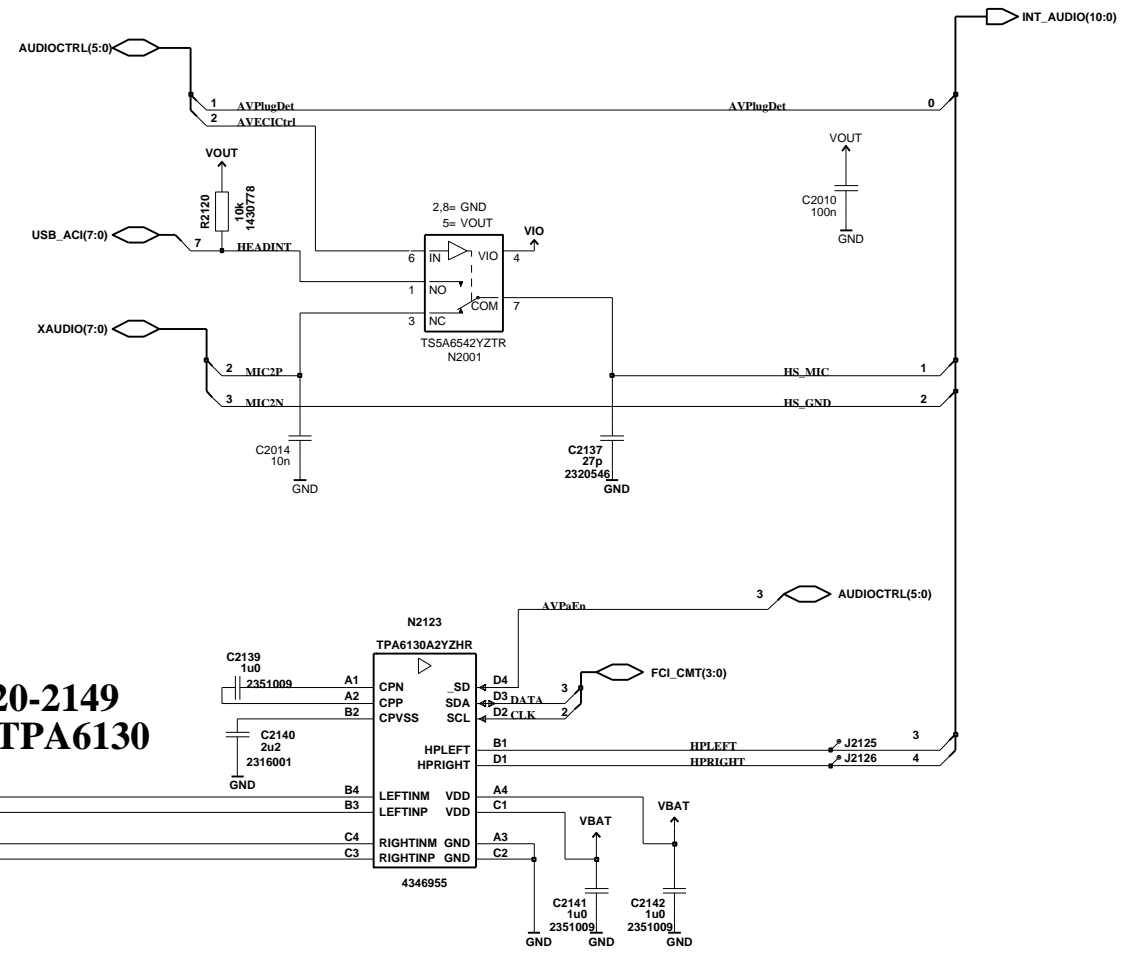

Mic



IHF-connection

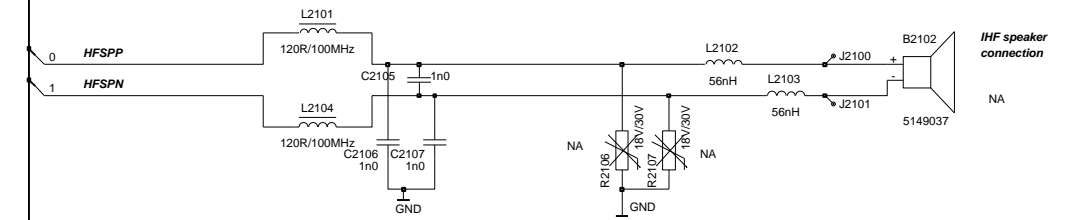

Earpiece

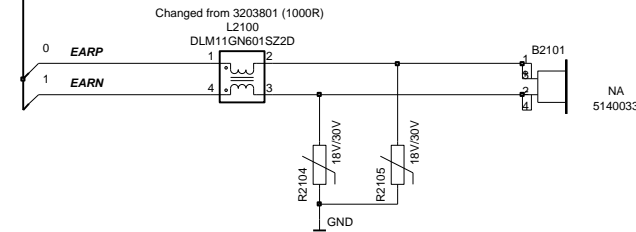

Vibra

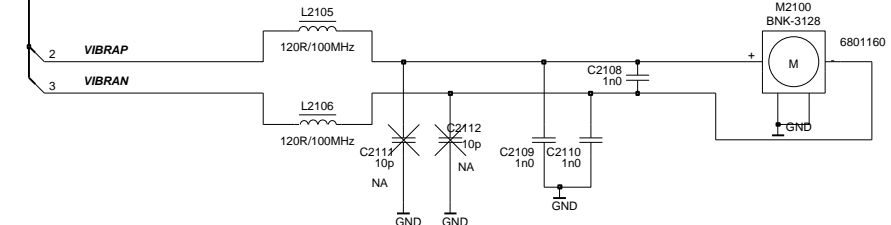

- ◇ GEN_CTRL_CMT(20:0)
- ◇ COMP_VIDEO
- ◇ DMIC(4:0)
- ◇ DIG_AUDIO(5:0)
- ◇ XAUDIO(7:0)
- ◇ I2C(1:0)
- ◇ AUDIOCTRL(5:0)
- ◇ H_BRIDGE(3:0)

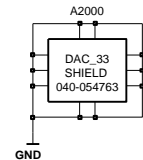

Copyright (C) Nokia Corporation. All rights reserved.
THIS DRAWING IS PROTECTED BY COPYRIGHT AS AN UNPUBLISHED WORK.
UNAUTHORIZED REPRODUCTION OF THIS DRAWING IS NOT PERMITTED.
THIS DRAWING CONTAINS PROPRIETARY AND CONFIDENTIAL INFORMATION.
This document is property of Nokia Corporation



Name	Audio sheet with DAC33		Appr	dd-mmm-yy
Assoc			Des.	04-Sep-02
File			Dr.	28-Mar-08
Proj			Sheet	35 of 50
			Print	Yes
			v.	0
			Edt	61

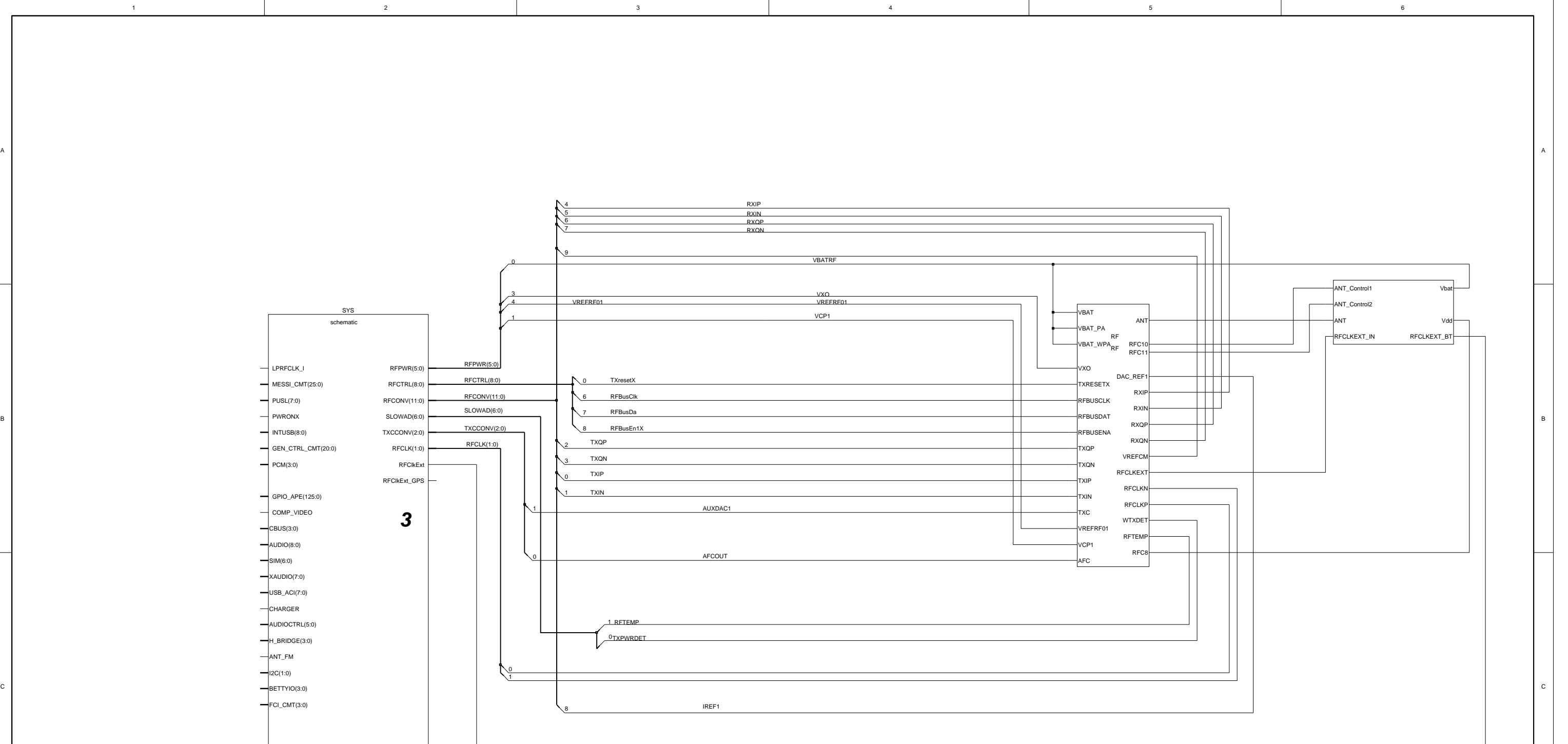

3

1

Copyright (C) Nokia Corporation. All rights reserved.
 THIS DRAWING IS PROTECTED BY COPYRIGHT AS AN UNPUBLISHED WORK.
 UNAUTHORIZED REPRODUCTION OF THIS DRAWING IS NOT PERMITTED.
 THIS DRAWING CONTAINS PROPRIETARY AND CONFIDENTIAL INFORMATION.
 This document is property of Nokia Corporation



Name	BB & RF	Appr	dd-mmm-yy
Assoc		Des.	18-Nov-03
File		Dr.	16-Nov-07
Proj		Sheet	xx of yy
		Print	Yes
		V.	0.0
		Edt	19

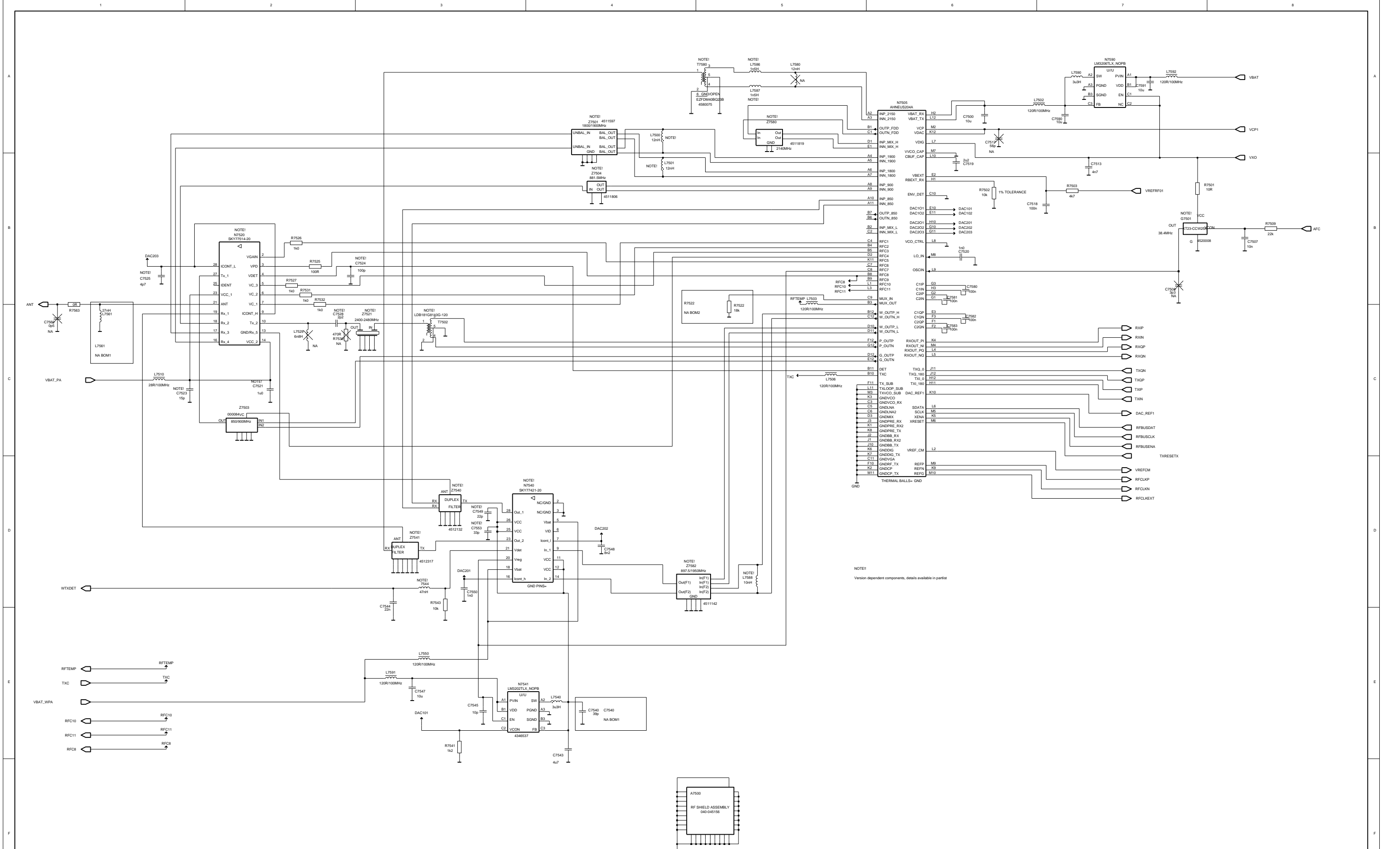

R50_18

Copyright (C) Nokia Corporation. All rights reserved.
 THIS DRAWING IS PROTECTED BY COPYRIGHT AS AN UNPUBLISHED WORK.
 UNAUTHORIZED REPRODUCTION OF THIS DRAWING IS NOT PERMITTED.
 THIS DRAWING CONTAINS PROPRIETARY AND CONFIDENTIAL INFORMATION.
 This document is property of Nokia Corporation

NOKIA

Name	r50_engine	Appr	dd-mmm-yy
Assoc		Des	22-Jun-05
File		Ch	26-Feb-08
Proj		Sheet	xx of yy
		Print	Yes
		Ver	0.0
		Edt	222

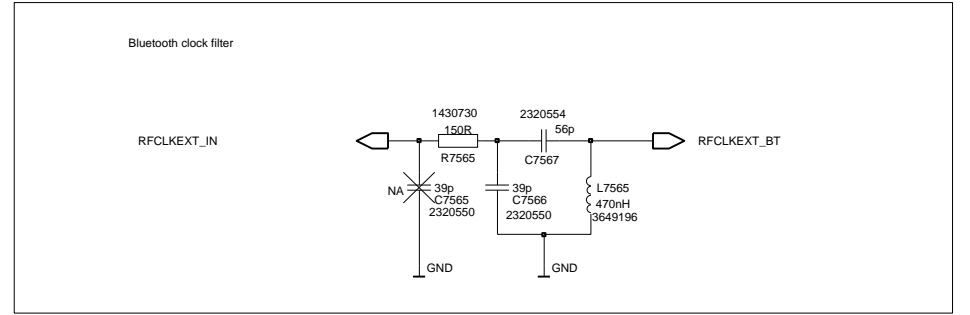
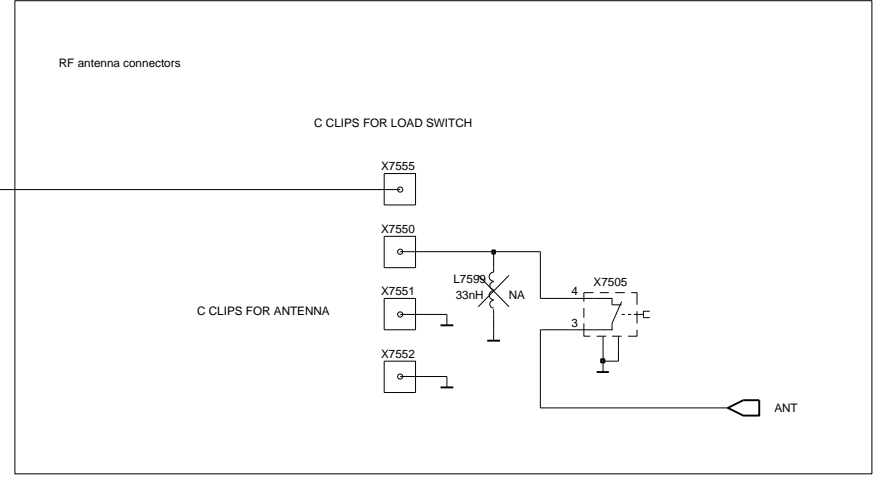
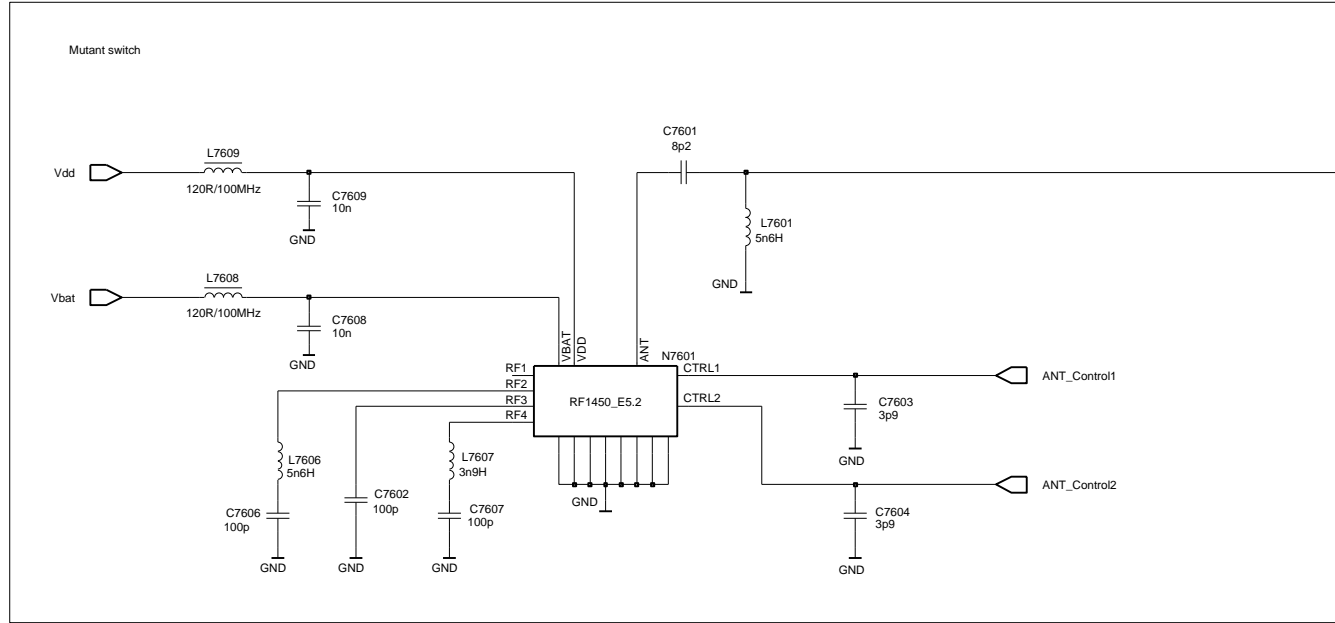

Copyright (C) Nokia Corporation. All rights reserved.
 THIS DRAWING IS PROTECTED BY COPYRIGHT AS AN UNPUBLISHED WORK.
 UNAUTHORIZED REPRODUCTION OF THIS DRAWING IS NOT PERMITTED.
 THIS DRAWING CONTAINS PROPRIETARY AND CONFIDENTIAL INFORMATION.
 This document is property of Nokia Corporation



Name		Appr	dd-mmm-yy
Assoc		Des.	08-Nov-05
		Dr.	12-Mar-08
File		Sheet	xx of yy 01
Proj	Drw.	Print	Yes V. 0.0 Edit 30

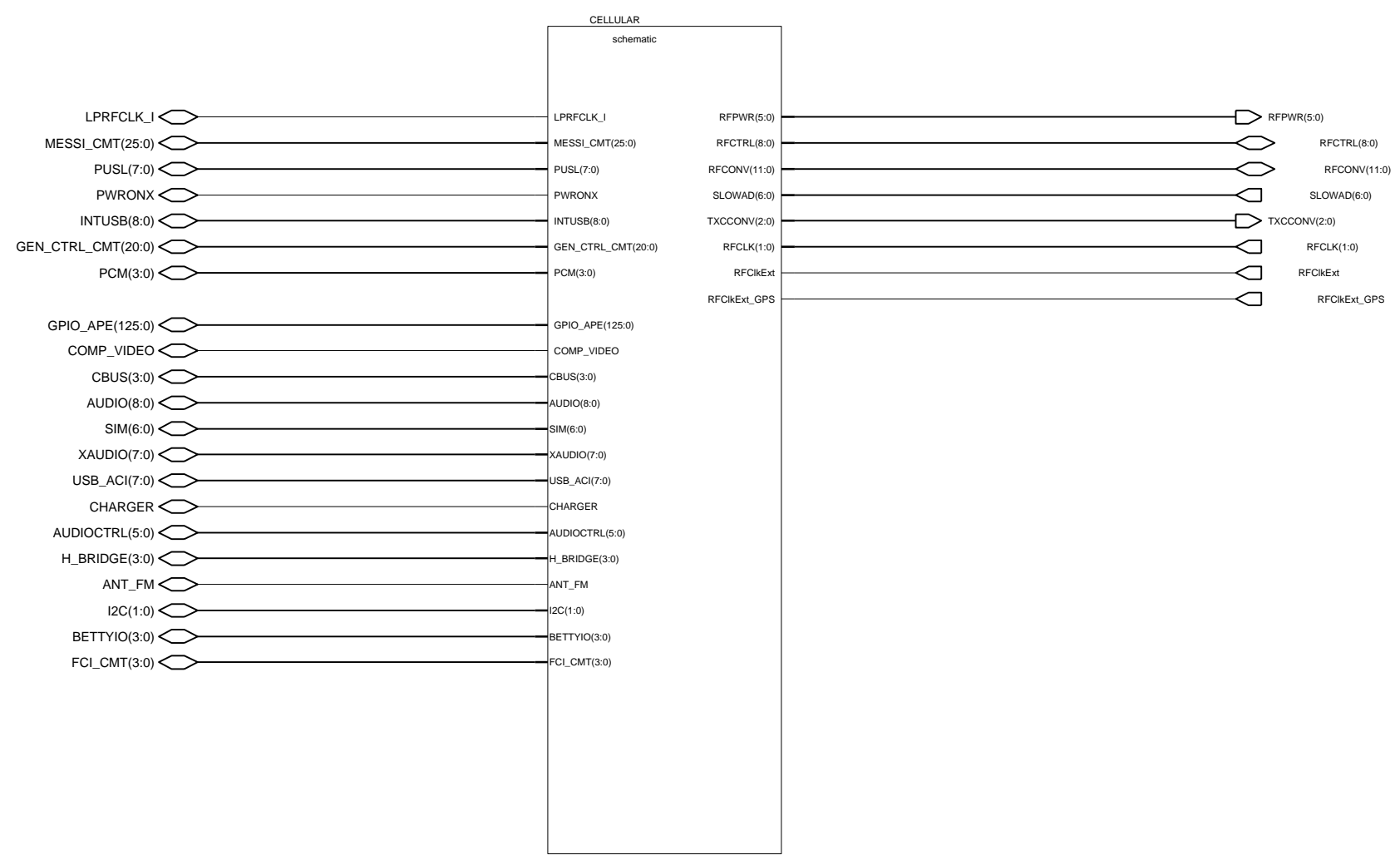

Copyright (C) Nokia Corporation. All rights reserved.
 THIS DRAWING IS PROTECTED BY COPYRIGHT AS AN UNPUBLISHED WORK.
 UNAUTHORIZED REPRODUCTION OF THIS DRAWING IS NOT PERMITTED.
 THIS DRAWING CONTAINS PROPRIETARY AND CONFIDENTIAL INFORMATION.
 This document is property of Nokia Corporation



Name BB Top Level		Appr dd-mmm-yy	
Assoc	Build	Des. 24-Sep-04	
File		Dr. 24-Sep-07	
Proj		Sheet xx of yy	0 (01)
Print Yes		V. 02	Edit 7

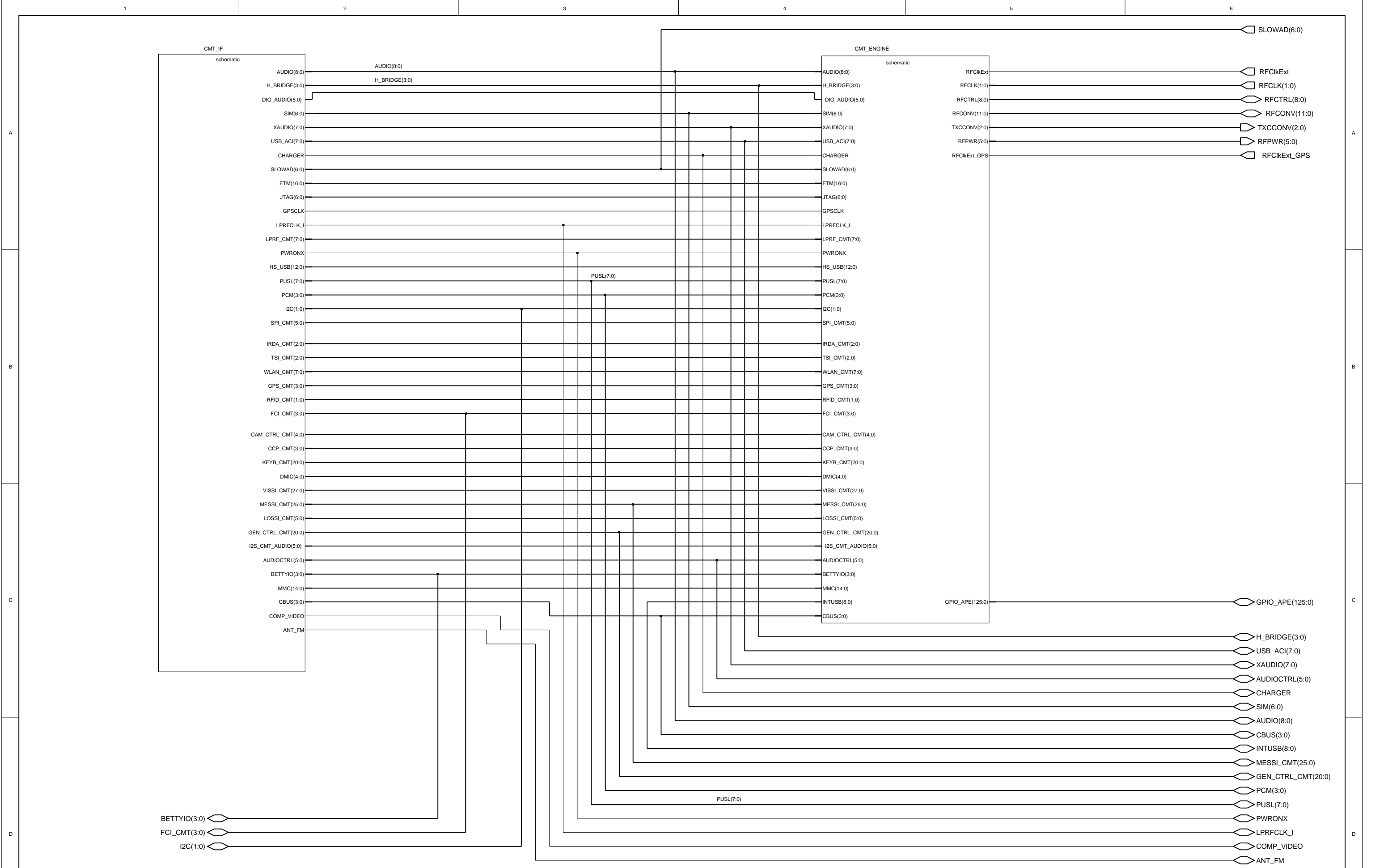

Copyright (C) Nokia Corporation. All rights reserved.
 THIS DRAWING IS PROTECTED BY COPYRIGHT AS AN UNPUBLISHED WORK.
 UNAUTHORIZED REPRODUCTION OF THIS DRAWING IS NOT PERMITTED.
 THIS DRAWING CONTAINS PROPRIETARY AND CONFIDENTIAL INFORMATION.
 This document is property of Nokia Corporation



Name	Cellular Top Level	Appr	dd-mmm-yy
Assoc		Des.	24-Sep-04
File		Dr.	17-Sep-07
Proj		Sheet	xx of yy
		Print	Yes
		v.	0
		Edit	6

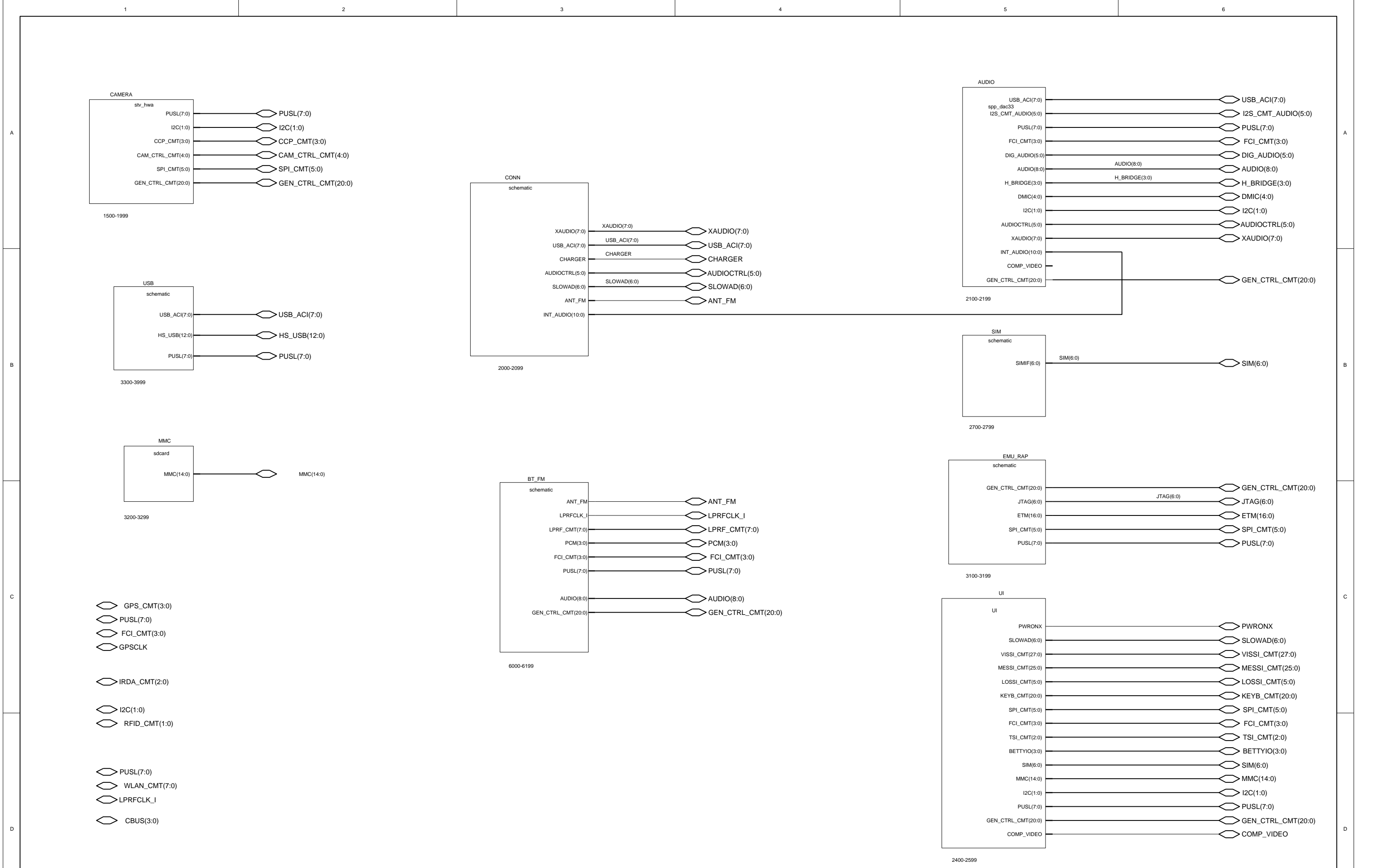

Copyright (C) Nokia Corporation. All rights reserved. THIS DRAWING IS PROTECTED BY COPYRIGHT AS AN UNPUBLISHED WORK. UNAUTHORIZED REPRODUCTION OF THIS DRAWING IS NOT PERMITTED. THIS DRAWING CONTAINS PROPRIETARY AND CONFIDENTIAL INFORMATION. This document is property of Nokia Corporation		NOKIA		Name CMT_IF Top Level		Appr dd-mmm-yy	
				Assoc		Des. 27-May-03	
				File		Dr. 15-Dec-07	
				Proj		Sheet xx of yy 0 (01)	
				Print Yes		V. 0,0 Edit 10	

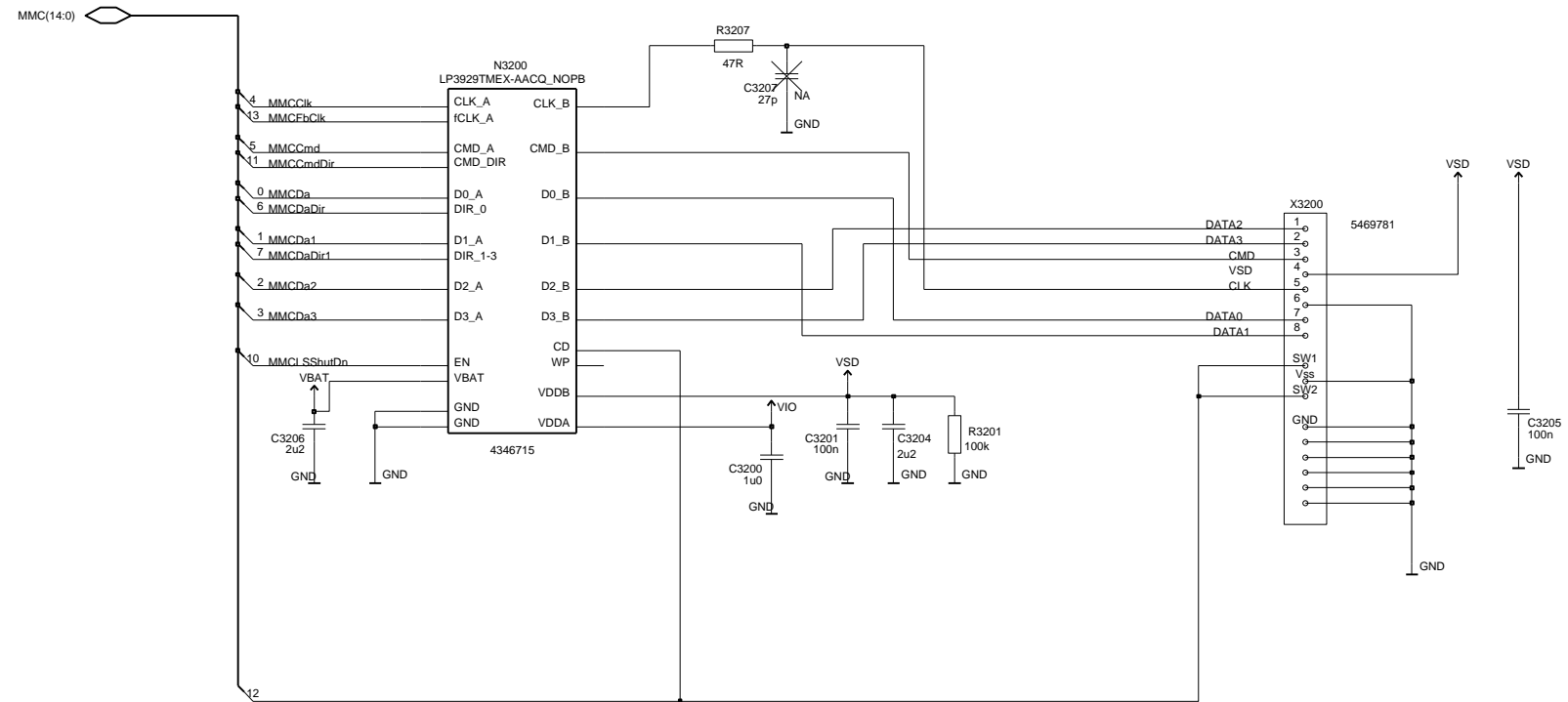

Copyright (C) Nokia Corporation. All rights reserved.
 THIS DRAWING IS PROTECTED BY COPYRIGHT AS AN UNPUBLISHED WORK.
 UNAUTHORIZED REPRODUCTION OF THIS DRAWING IS NOT PERMITTED.
 THIS DRAWING CONTAINS PROPRIETARY AND CONFIDENTIAL INFORMATION.
 This document is property of Nokia Corporation



Name	SD card	Appr	dd-mmm-yy
Assoc		Des.	11-Apr-05
File		Dr.	20-Feb-08
Proj		Sheet xx of yy	0 (01)
		Print Yes	v. 0.0 Edit 10

- I2C(1:0)
- COMP_VIDEO
- VISSI_CMT(27:0)
- LOSSI_CMT(5:0)
- FCL_CMT(3:0)
- SPL_CMT(5:0)
- PUSL(7:0)
- GEN_CTRL_CMT(20:0)
- PWRONX
- SLOWAD(6:0)
- SIM(6:0)
- MMC(14:0)
- BETTYIO(3:0)
- MESSI_CMT(25:0)

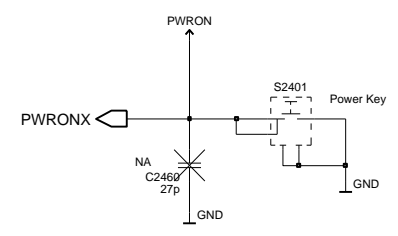

	Col0	Col1	Col2	Col3	Col4
Row0	Vol UP	1	2	3	RSK
Row1	Vol Down	4	5	6	LSK
Row2		7	8	9	Clear
Row3		*	0	#	Menu
Row4	Up	SEND	Camera	END	Down
Row5	Right				Left
Row6	Play	Previous/ Game	Game key	Select	Next

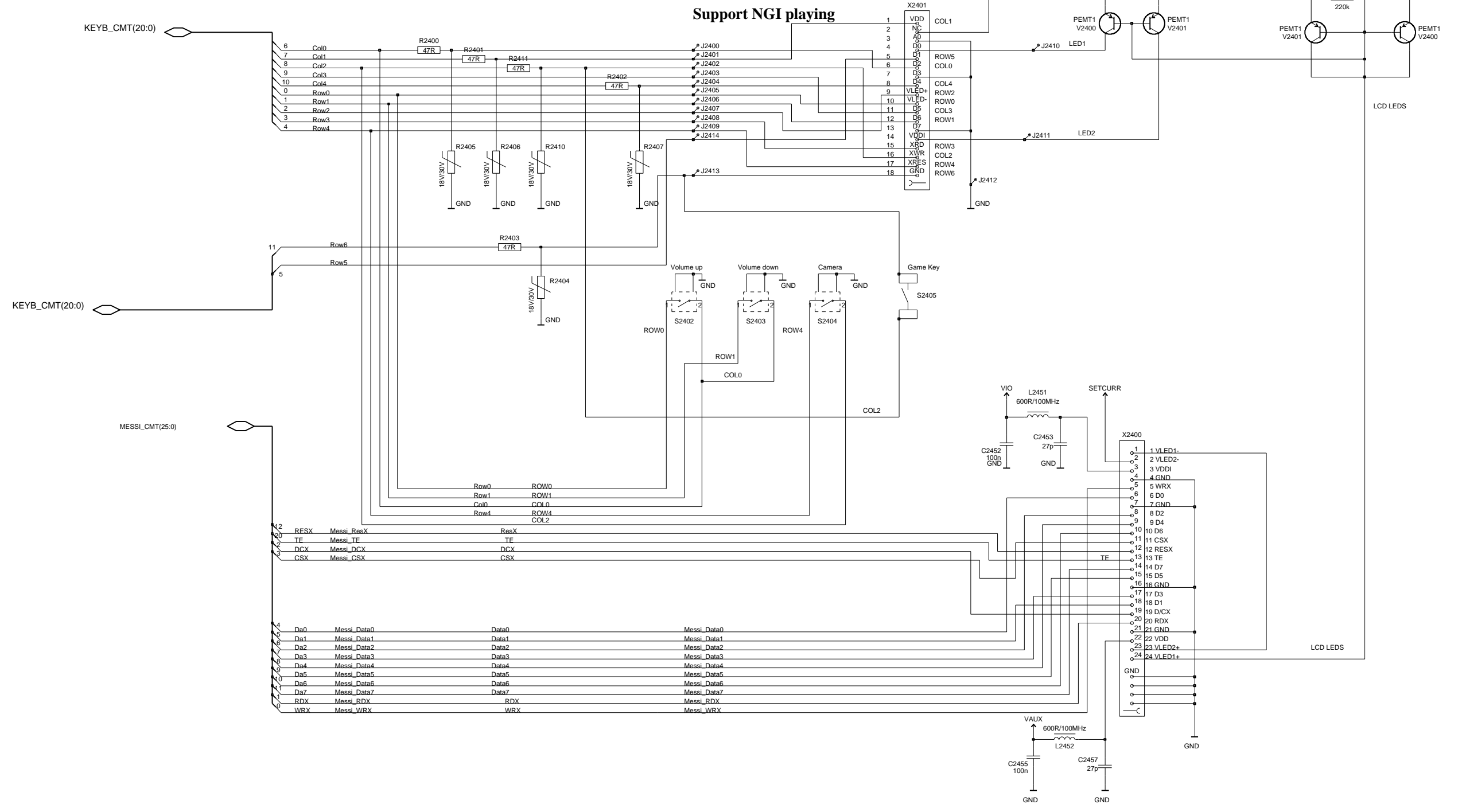

Support NGI playing

Pin	Signal
1	VDD
2	NC
3	AG
4	CG
5	D0
6	D1
7	D2
8	D3
9	VLED+
10	VLED-
11	D5
12	D6
13	D7
14	VDDI
15	XRD
16	XWR
17	XRES
18	GND

Copyright (C) Nokia Corporation. All rights reserved.
 THIS DRAWING IS PROTECTED BY COPYRIGHT AS AN UNPUBLISHED WORK.
 UNAUTHORIZED REPRODUCTION OF THIS DRAWING IS NOT PERMITTED.
 THIS DRAWING CONTAINS PROPRIETARY AND CONFIDENTIAL INFORMATION.
 This document is property of Nokia Corporation

Name: UI parts		Appr: dd-mmm-yy	
Assoc:		Des: 21-Apr-05	
		Dr: 28-Mar-08	
File:		Sheet xx of yy: 0 (01)	
Pro:		Print Yes v. 0.0 Edit 48	

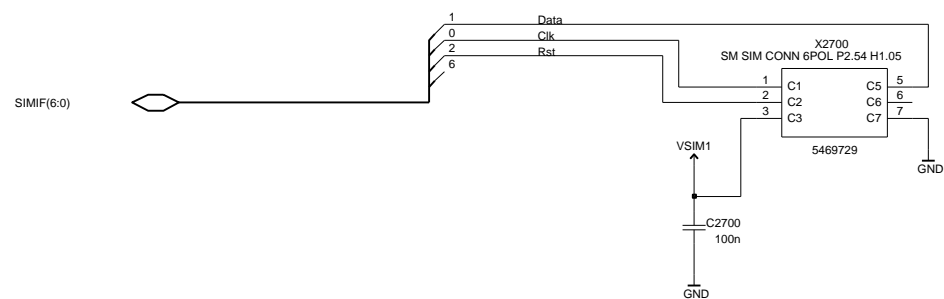

Copyright (C) Nokia Corporation. All rights reserved.
 THIS DRAWING IS PROTECTED BY COPYRIGHT AS AN UNPUBLISHED WORK.
 UNAUTHORIZED REPRODUCTION OF THIS DRAWING IS NOT PERMITTED.
 THIS DRAWING CONTAINS PROPRIETARY AND CONFIDENTIAL INFORMATION.
 This document is property of Nokia Corporation



Name	SIM interface	Appr	10-Aug-00
Assoc		Des.	10-May-04
File		Dr.	16-Dec-07
Proj		Sheet	xx of yy
		Print	Yes v. Edit
			1 (01) 5

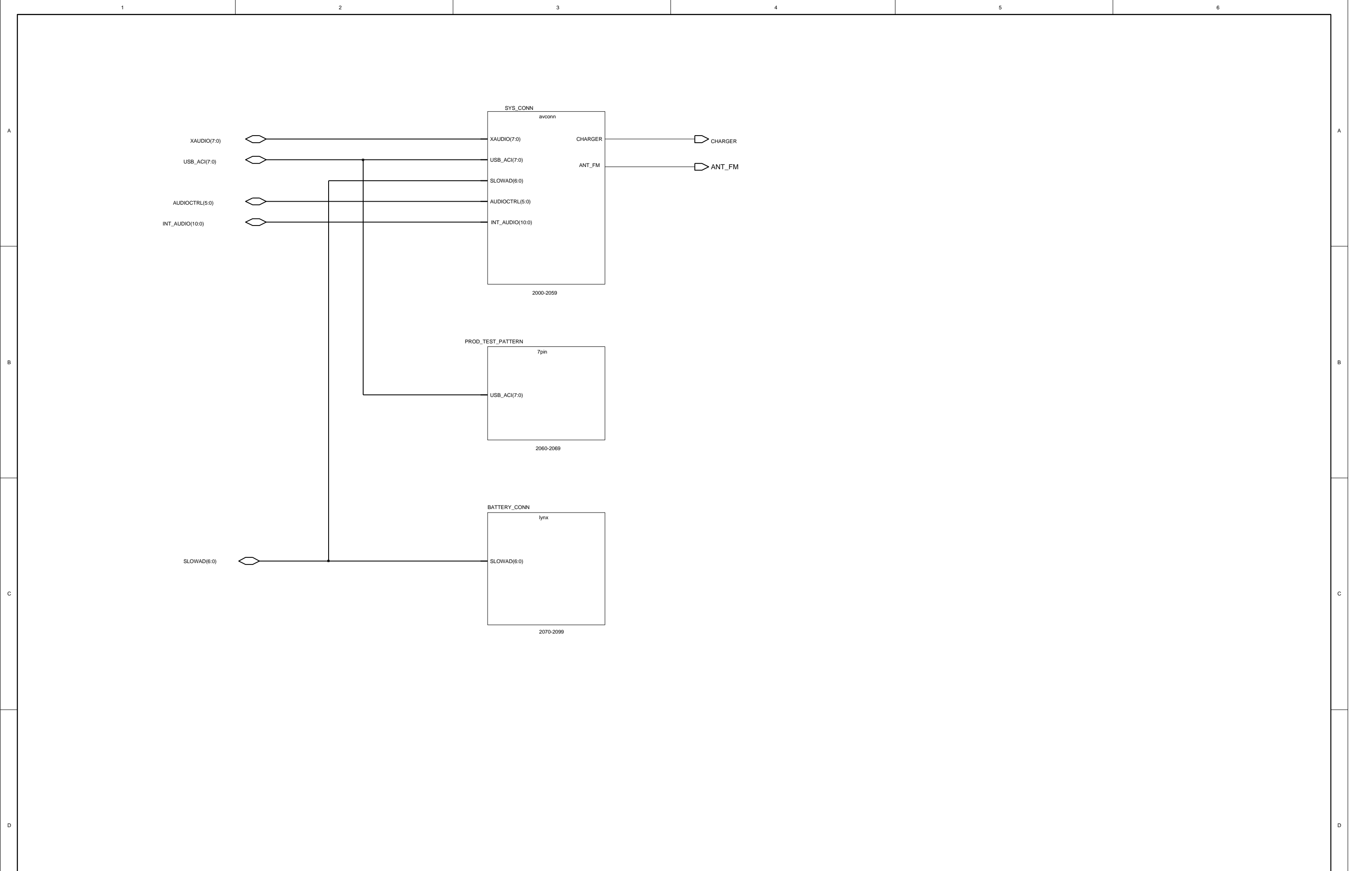

Copyright (C) Nokia Corporation. All rights reserved.
 THIS DRAWING IS PROTECTED BY COPYRIGHT AS AN UNPUBLISHED WORK.
 UNAUTHORIZED REPRODUCTION OF THIS DRAWING IS NOT PERMITTED.
 THIS DRAWING CONTAINS PROPRIETARY AND CONFIDENTIAL INFORMATION.
 This document is property of Nokia Corporation



Name	System and battery connector		Appr	10-Aug-00
Assoc			Des.	18-Jan-02
File			Dr.	17-Sep-07
Proj		Drw.	Sheet xx of yy	1 (01)
			Print Yes	V. 0,1 Edit 6

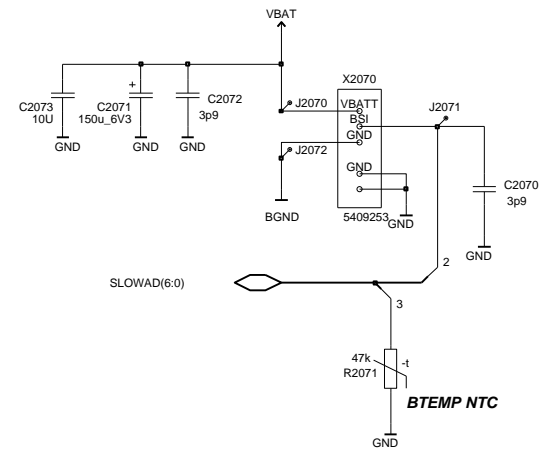

Copyright (C) Nokia Corporation. All rights reserved.
 THIS DRAWING IS PROTECTED BY COPYRIGHT AS AN UNPUBLISHED WORK.
 UNAUTHORIZED REPRODUCTION OF THIS DRAWING IS NOT PERMITTED.
 THIS DRAWING CONTAINS PROPRIETARY AND CONFIDENTIAL INFORMATION.
 This document is property of Nokia Corporation



Name	Battery Connector	Appr	10-Aug-00
Assoc	BUILD	Des.	18-Aug-03
File		Dr.	28-Mar-08
Proj	Drw.	Sheet XX of yy	1 (01)
		Print Yes v. 02	Edit 15

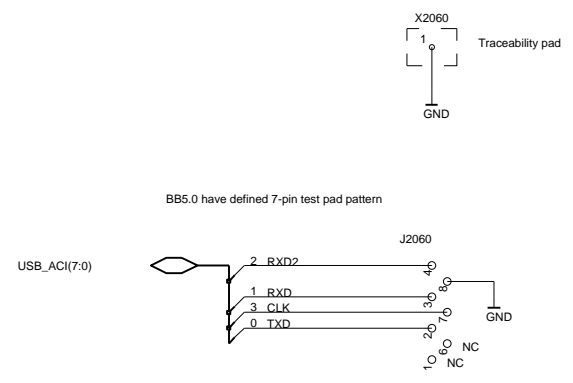

Copyright (C) Nokia Corporation. All rights reserved.
 THIS DRAWING IS PROTECTED BY COPYRIGHT AS AN UNPUBLISHED WORK.
 UNAUTHORIZED REPRODUCTION OF THIS DRAWING IS NOT PERMITTED.
 THIS DRAWING CONTAINS PROPRIETARY AND CONFIDENTIAL INFORMATION.
 This document is property of Nokia Corporation



Name	Production test pad	Appr	10-Aug-00
Assoc		Des.	18-Jan-02
File		Dr.	15-Dec-07
Proj		Sheet	xx of yy
		Print	Yes
		V.	0,1
		Edit	4
			1 (01)

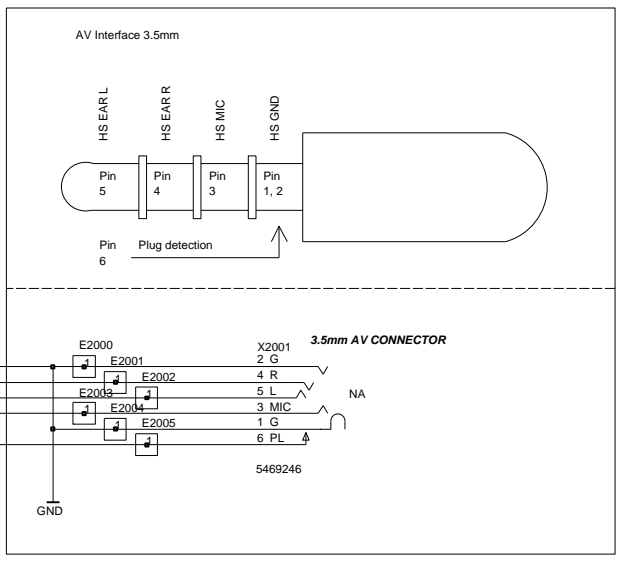
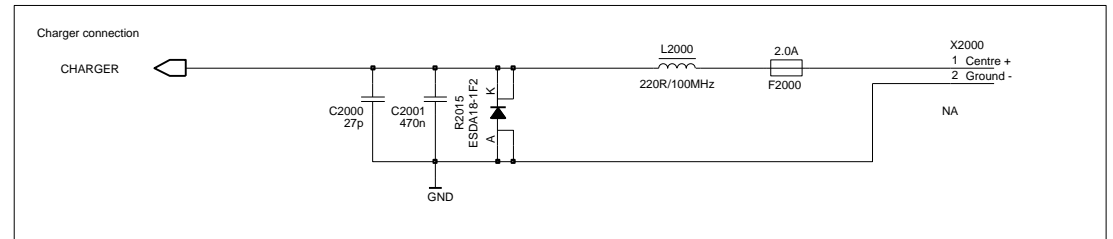

**AV CONN
REF AREA 2010-2029**

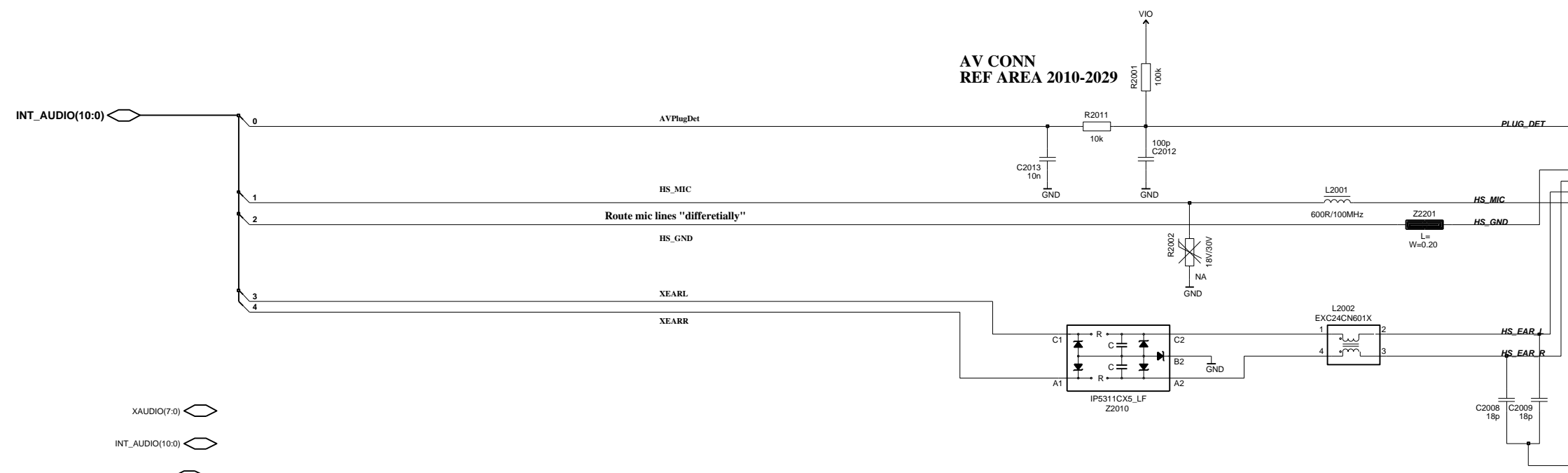

- XAUDIO(7:0)
- INT_AUDIO(10:0)
- AUDIOCTRL(5:0)
- SLOWAD(6:0)
- USB_ACI(7:0)

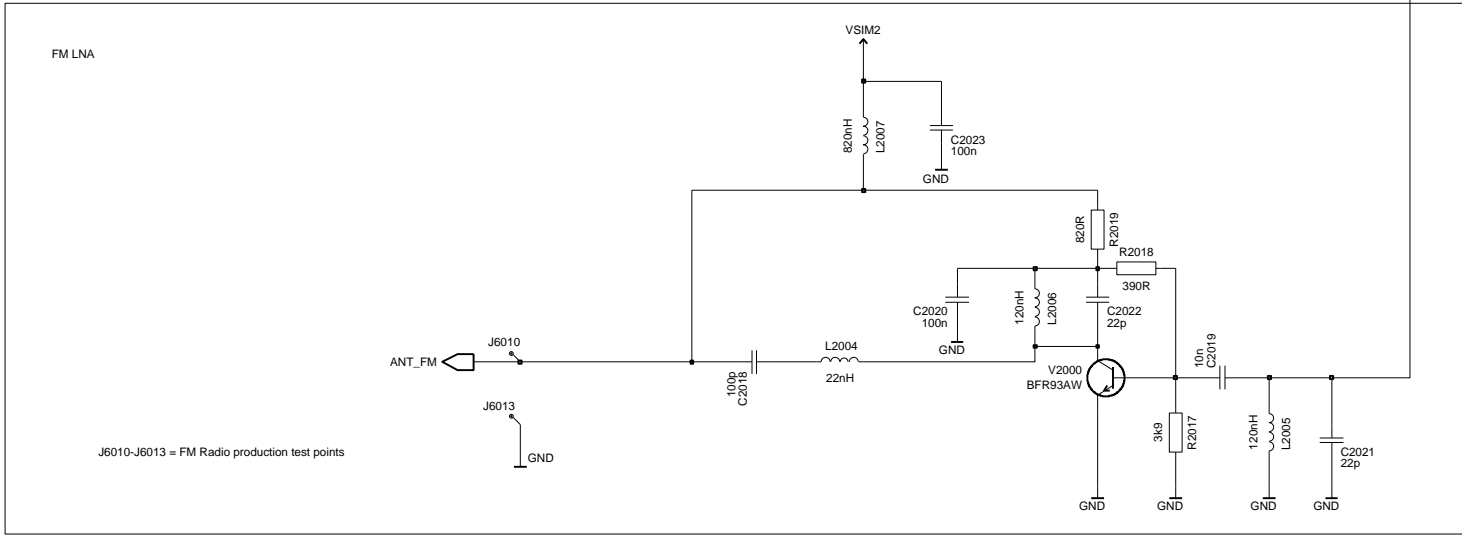

Copyright (C) Nokia Corporation. All rights reserved.
 THIS DRAWING IS PROTECTED BY COPYRIGHT AS AN UNPUBLISHED WORK.
 UNAUTHORIZED REPRODUCTION OF THIS DRAWING IS NOT PERMITTED.
 THIS DRAWING CONTAINS PROPRIETARY AND CONFIDENTIAL INFORMATION.
 This document is property of Nokia Corporation



Name	AV connector, Audio, Video and ECI control	Appr	dd-mmm-yy
Assoc		Des.	18-Apr-05
File		Dr.	15-Dec-07
Proj		Sheet	xx of yy
		Print	Yes
		V.	2.0
		Edit	27

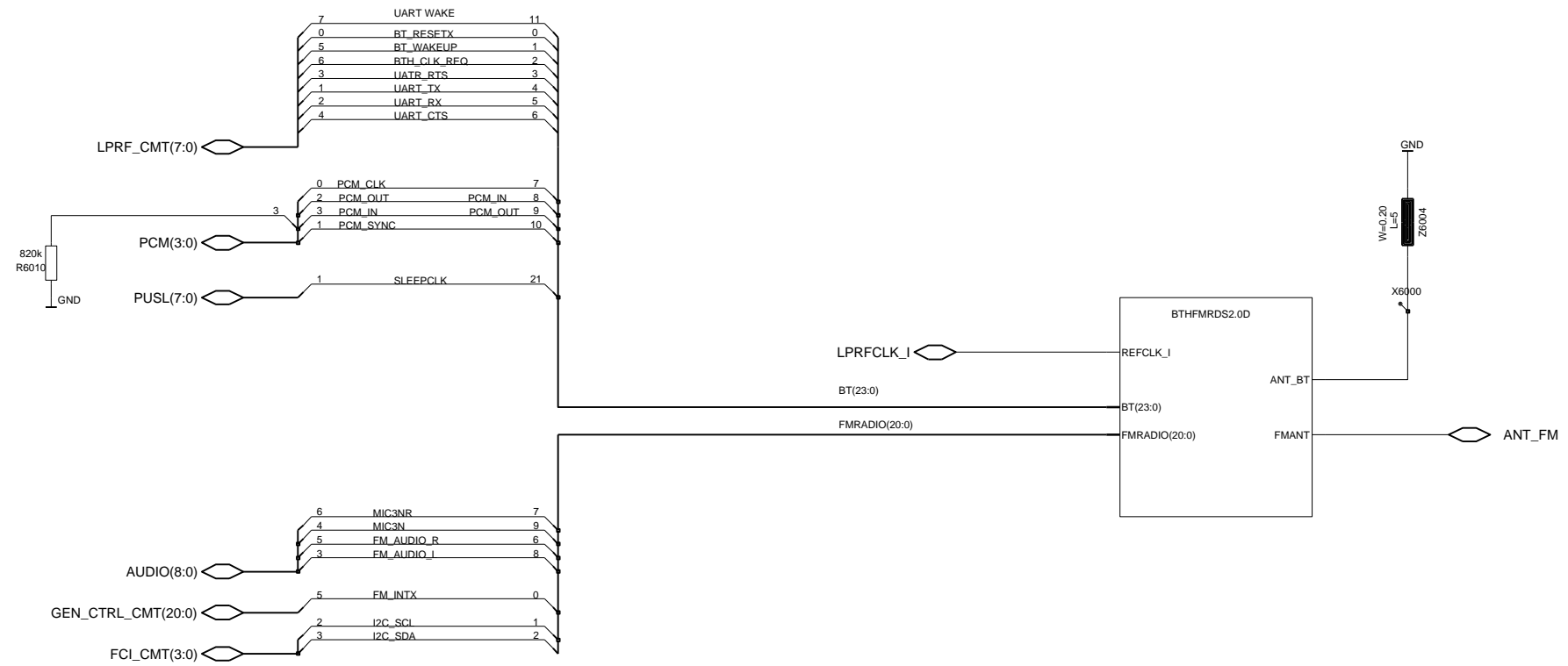

Copyright (C) Nokia Corporation. All rights reserved.
 THIS DRAWING IS PROTECTED BY COPYRIGHT AS AN UNPUBLISHED WORK.
 UNAUTHORIZED REPRODUCTION OF THIS DRAWING IS NOT PERMITTED.
 THIS DRAWING CONTAINS PROPRIETARY AND CONFIDENTIAL INFORMATION.
 This document is property of Nokia Corporation



Name	Bluetooth - FM	Appr	dd-mmm-yy
Assoc		Des.	13-May-05
File		Dr.	16-Jan-08
Proj		Sheet xx of yy	0 (01)
		Print Yes	v. 0.0 Edit 7

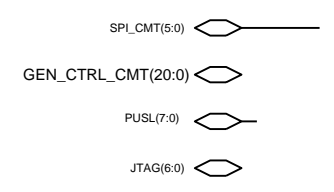
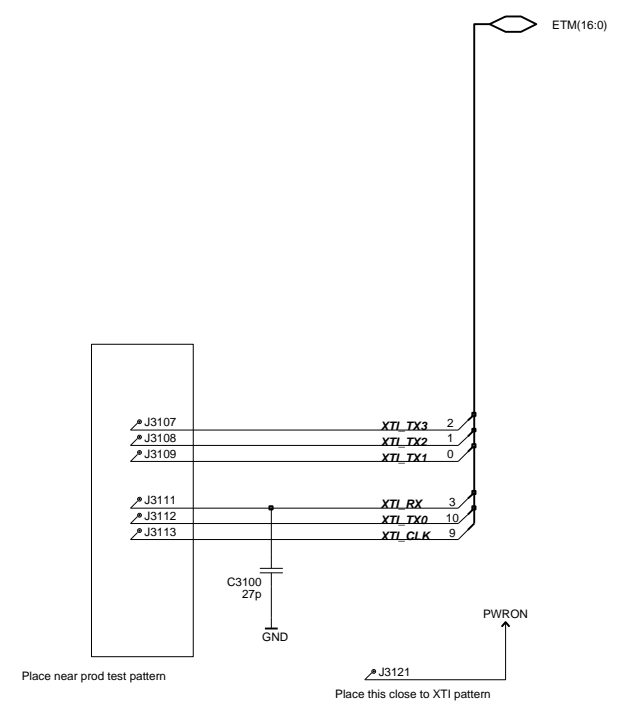

Copyright (C) Nokia Corporation. All rights reserved.
 THIS DRAWING IS PROTECTED BY COPYRIGHT AS AN UNPUBLISHED WORK.
 UNAUTHORIZED REPRODUCTION OF THIS DRAWING IS NOT PERMITTED.
 THIS DRAWING CONTAINS PROPRIETARY AND CONFIDENTIAL INFORMATION.
 This document is property of Nokia Corporation



Name		EMU:RAP Test Interface		Appr		dd-mmm-yy	
Assoc				Des.		04-Jun-98	
File				Dr.		15-Dec-07	
Proj		Drw.		Sheet xx of yy		1 (01)	
				Print Yes		V. 1.3 Edit 12	

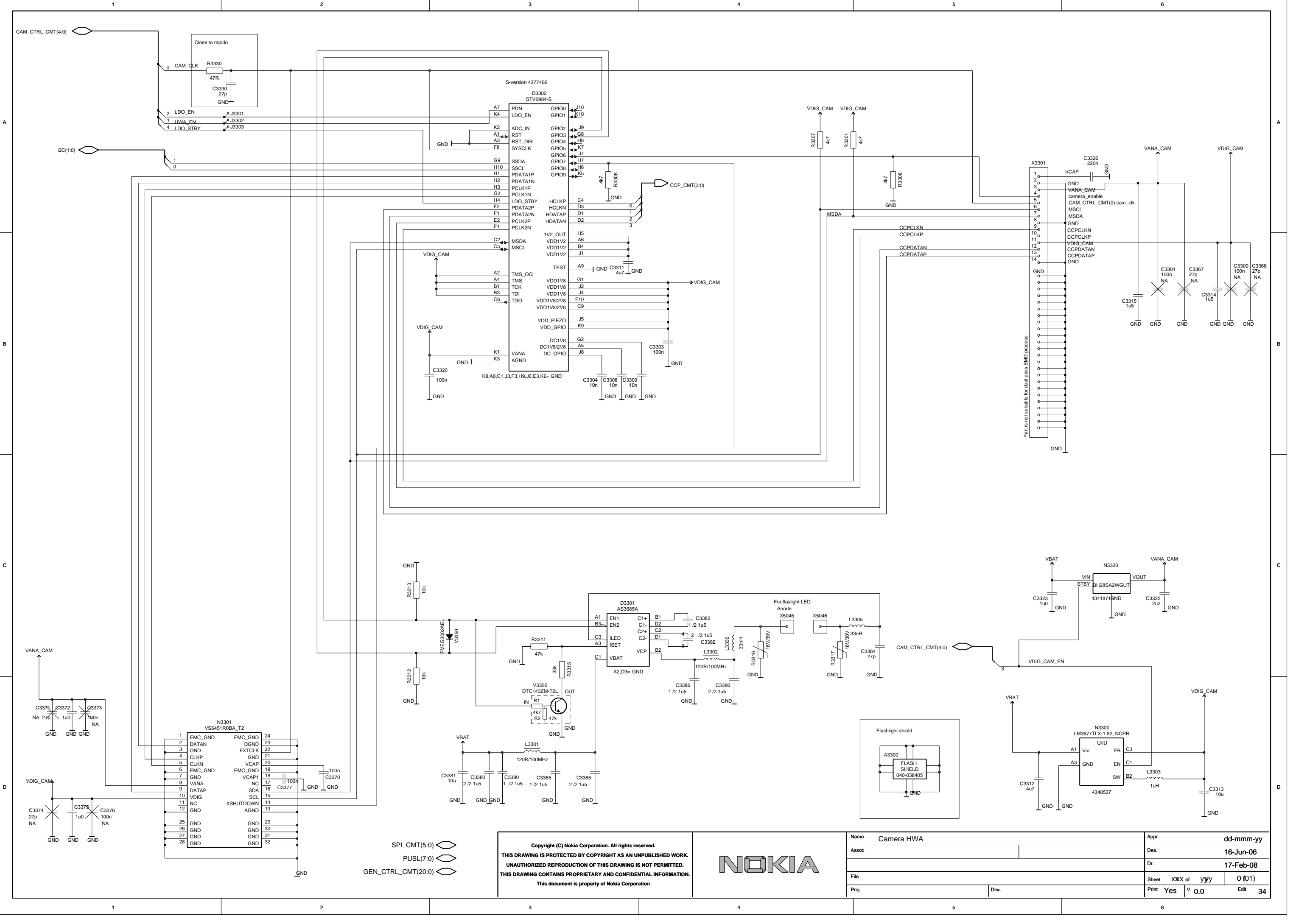

Copyright (C) Nokia Corporation. All rights reserved.
 THIS DRAWING IS PROTECTED BY COPYRIGHT AS AN UNPUBLISHED WORK.
 UNAUTHORIZED REPRODUCTION OF THIS DRAWING IS NOT PERMITTED.
 THIS DRAWING CONTAINS PROPRIETARY AND CONFIDENTIAL INFORMATION.
 This document is property of Nokia Corporation



Name	Camera HWA	Appr	dd-mmm-yy
Assoc		Des.	16-Jun-06
File		Dr.	17-Feb-08
Proj		Sheet	XXX of yyy
		Print	Yes
		V.	0.0
		Draw.	34

THIS SETUP IS DEVICE MODE ONLY!!!

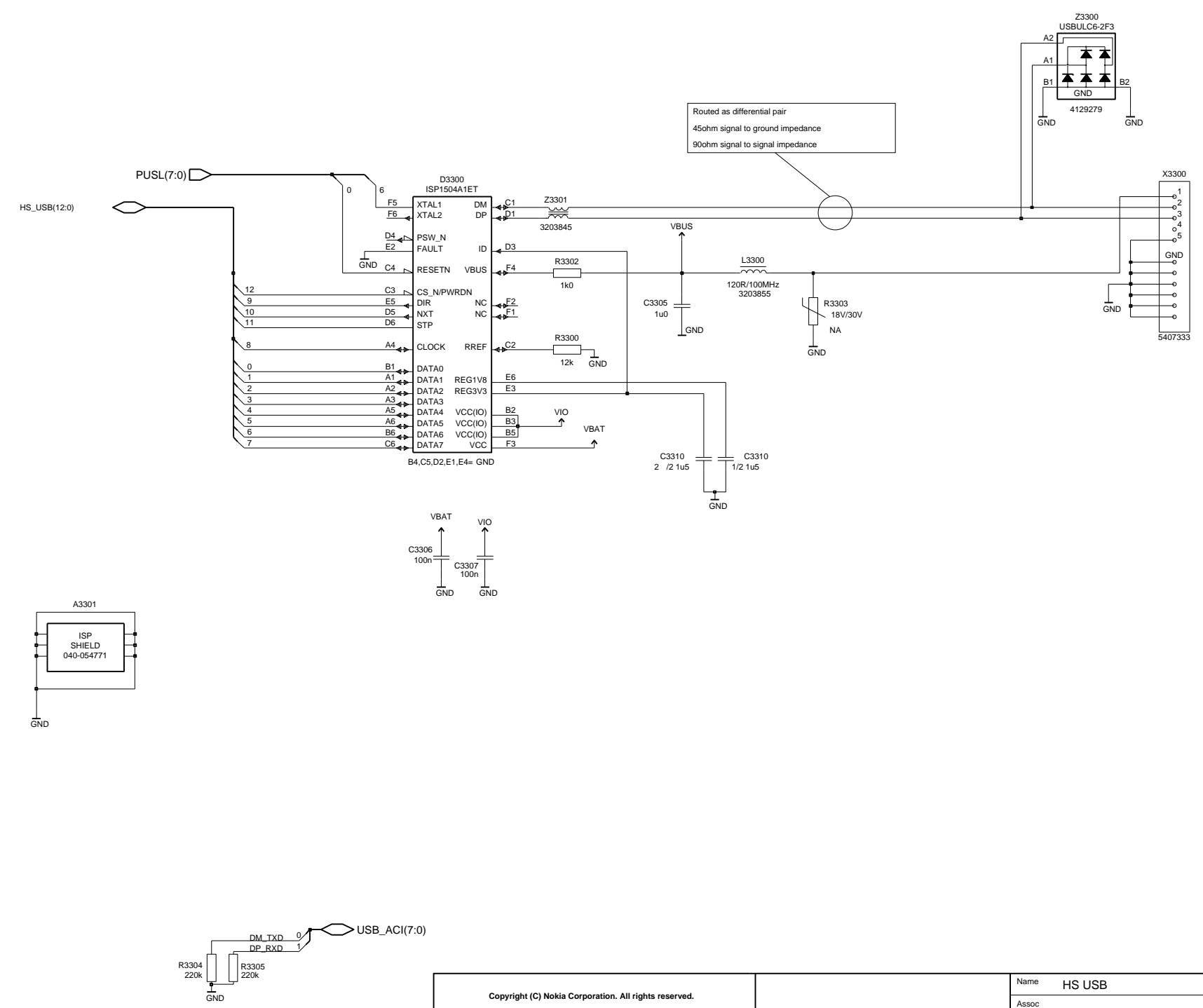

Copyright (C) Nokia Corporation. All rights reserved.
 THIS DRAWING IS PROTECTED BY COPYRIGHT AS AN UNPUBLISHED WORK.
 UNAUTHORIZED REPRODUCTION OF THIS DRAWING IS NOT PERMITTED.
 THIS DRAWING CONTAINS PROPRIETARY AND CONFIDENTIAL INFORMATION.
 This document is property of Nokia Corporation



Name	HS USB	Appr	dd-mmm-yy
Assoc		Des.	07-Apr-05
File		Dr.	15-Dec-07
Proj		Sheet	xx of yy
		Print	Yes
		V.	0.0
		Edit	13

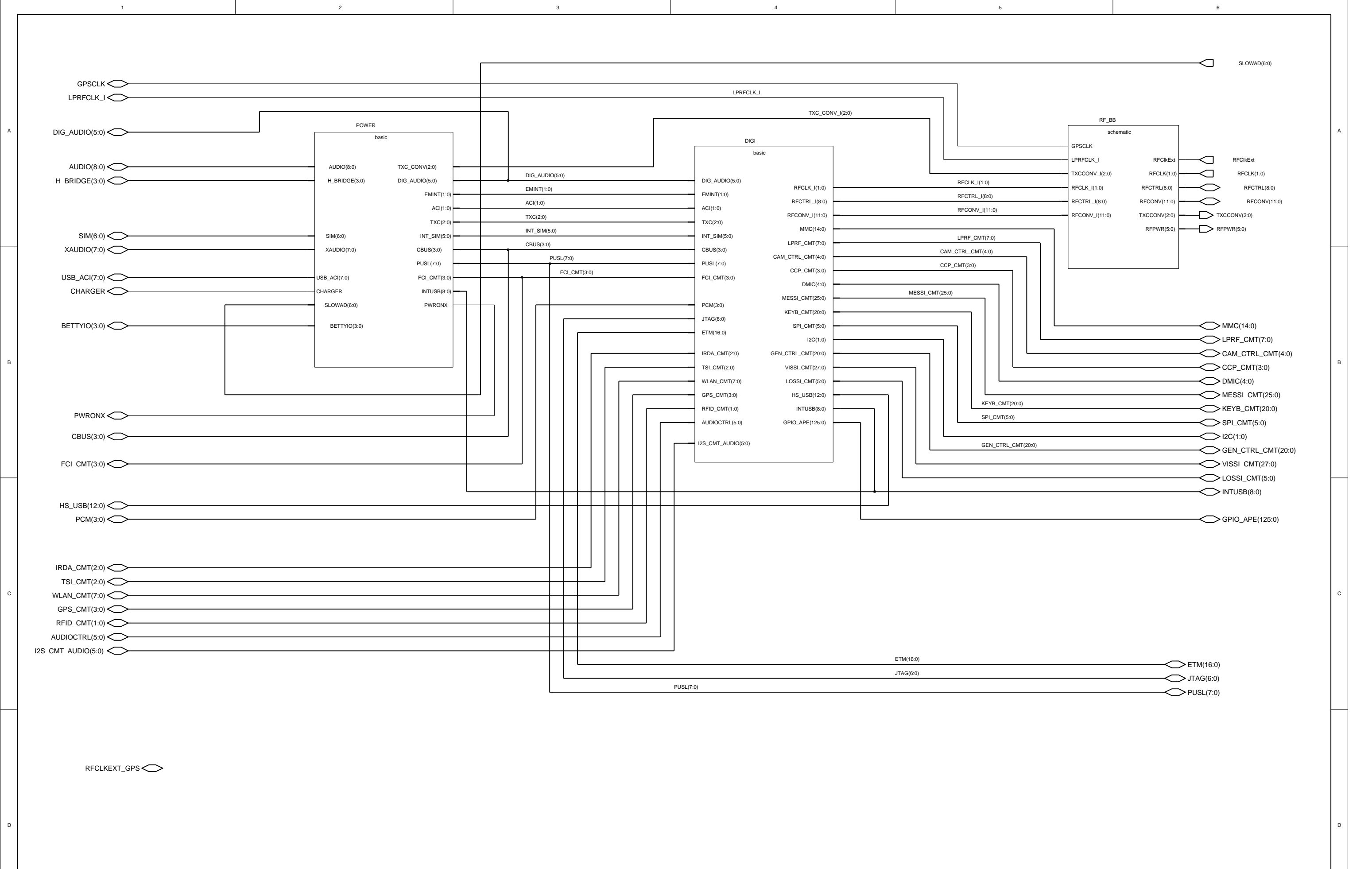

Copyright (C) Nokia Corporation. All rights reserved.
 THIS DRAWING IS PROTECTED BY COPYRIGHT AS AN UNPUBLISHED WORK.
 UNAUTHORIZED REPRODUCTION OF THIS DRAWING IS NOT PERMITTED.
 THIS DRAWING CONTAINS PROPRIETARY AND CONFIDENTIAL INFORMATION.
 This document is property of Nokia Corporation



Name	CMT_Engine Top level	Appr	dd-mmm-yy
Assoc		Des.	24-Sep-04
File		Dr.	24-Sep-07
Proj		Sheet	xx of yy
		Print	Yes
		v.	0,0
		Edit	7

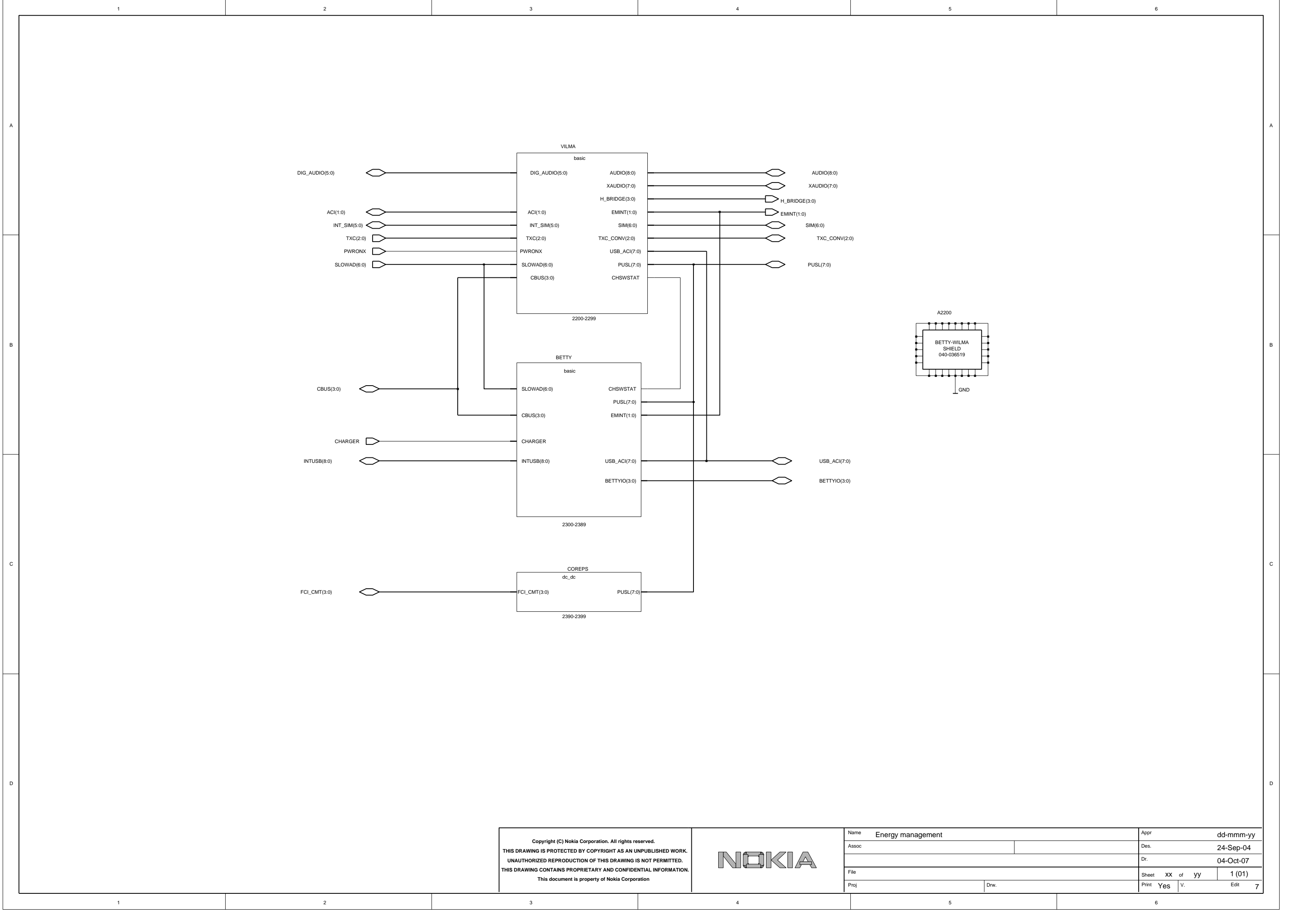

Copyright (C) Nokia Corporation. All rights reserved.
 THIS DRAWING IS PROTECTED BY COPYRIGHT AS AN UNPUBLISHED WORK.
 UNAUTHORIZED REPRODUCTION OF THIS DRAWING IS NOT PERMITTED.
 THIS DRAWING CONTAINS PROPRIETARY AND CONFIDENTIAL INFORMATION.
 This document is property of Nokia Corporation



Name Energy management		Appr dd-mmm-yy	
Assoc		Des. 24-Sep-04	
File		Dr. 04-Oct-07	
Proj		Sheet xx of yy 1 (01)	
Proj		Print Yes v. Edit 7	

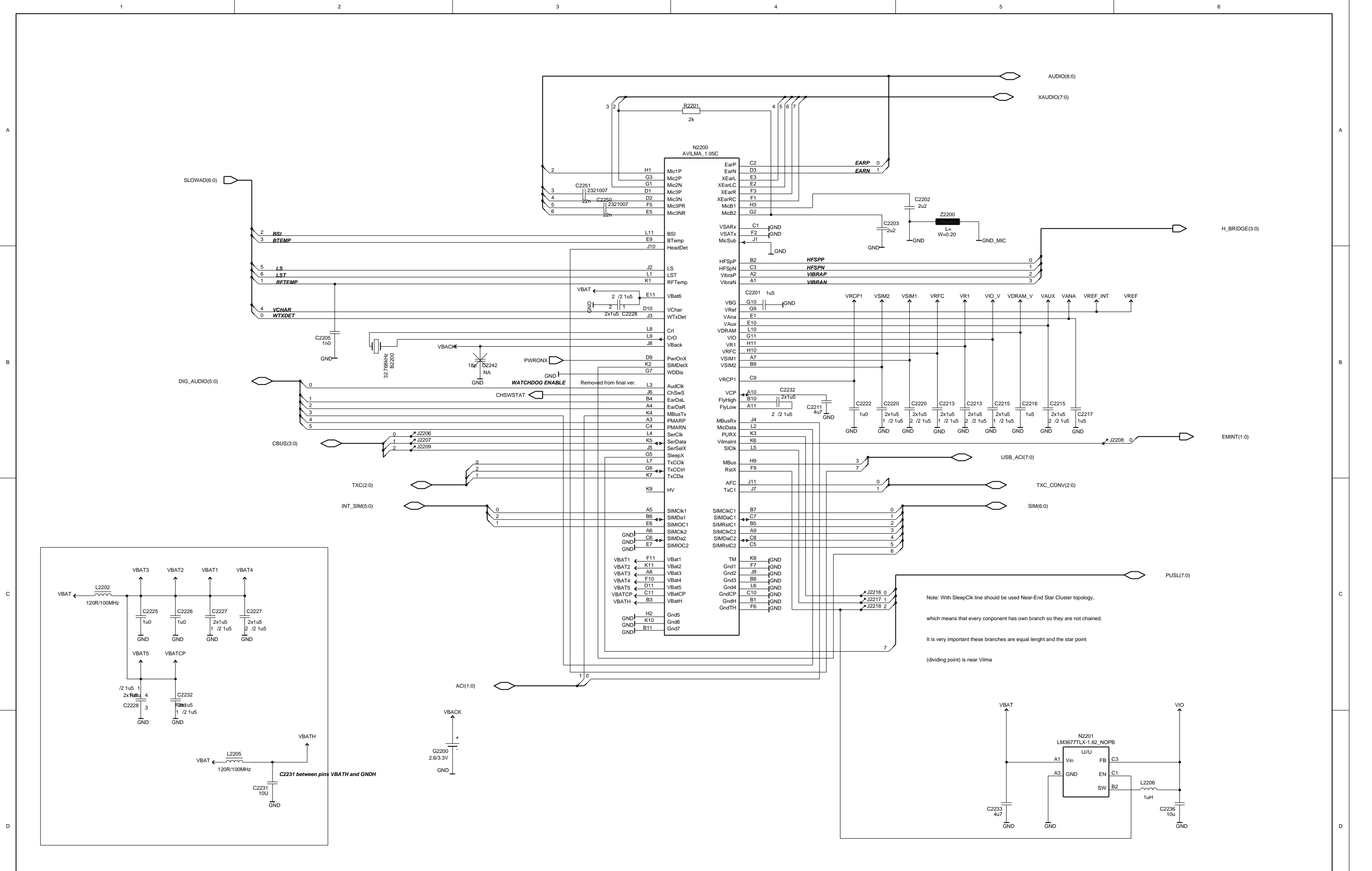

Copyright (C) Nokia Corporation. All rights reserved.
 THIS DRAWING IS PROTECTED BY COPYRIGHT AS AN UNPUBLISHED WORK.
 UNAUTHORIZED REPRODUCTION OF THIS DRAWING IS NOT PERMITTED.
 THIS DRAWING CONTAINS PROPRIETARY AND CONFIDENTIAL INFORMATION.
 This document is property of Nokia Corporation



Name	AVILMA	Appr	dd-mmm-yy
Assoc		Des.	22-Dec-05
File		Dr.	12-Mar-08
Proj		Sheet	xx of yy
		Print	Yes
		V.	0.0
		Edit	28

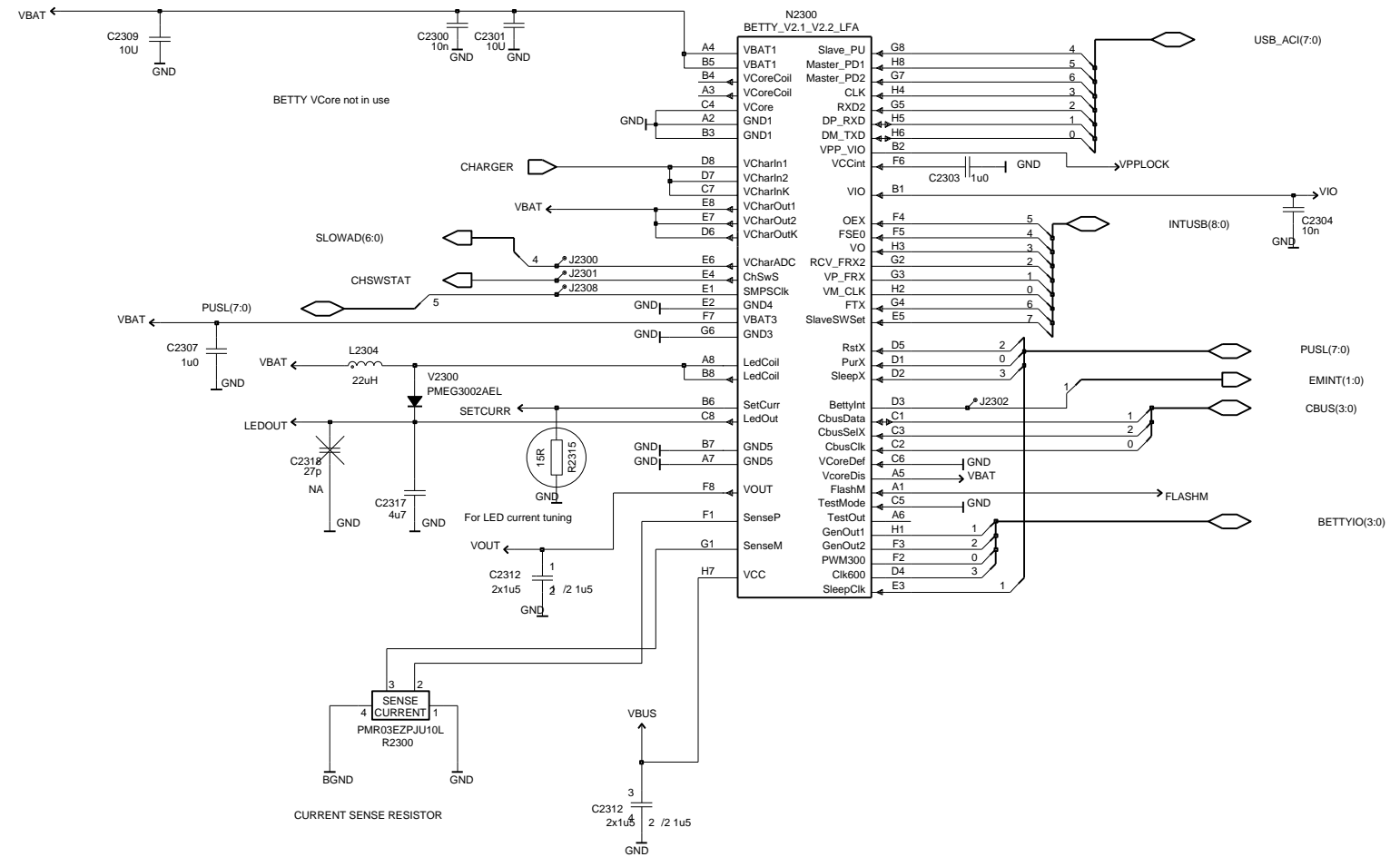

Copyright (C) Nokia Corporation. All rights reserved.
 THIS DRAWING IS PROTECTED BY COPYRIGHT AS AN UNPUBLISHED WORK.
 UNAUTHORIZED REPRODUCTION OF THIS DRAWING IS NOT PERMITTED.
 THIS DRAWING CONTAINS PROPRIETARY AND CONFIDENTIAL INFORMATION.
 This document is property of Nokia Corporation



Name	Betty	Appr	10-Aug-00
Assoc		Des.	06-May-04
		Dr.	18-Dec-07
File		Sheet	xx of yy
Proj		Print	Yes v. Edit
			22

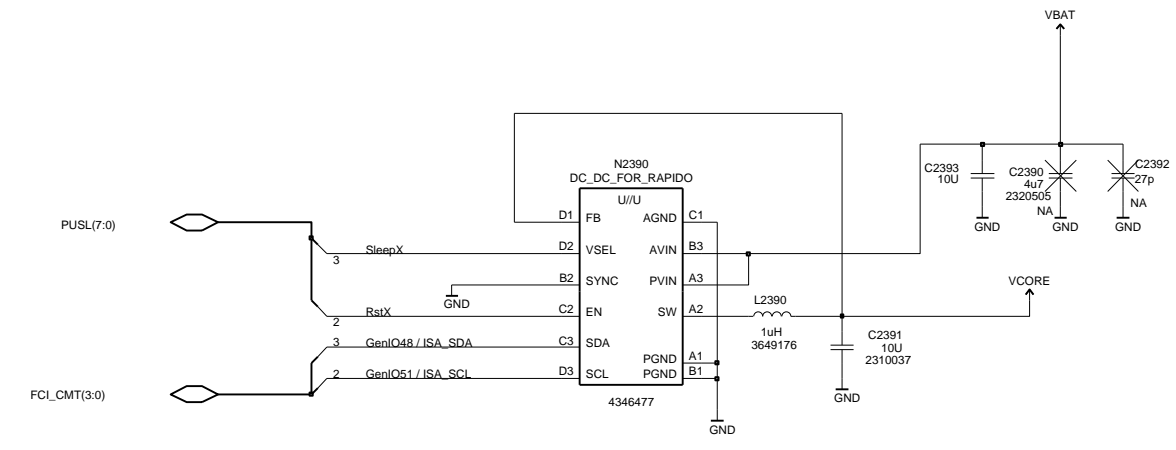

Copyright (C) Nokia Corporation. All rights reserved.
 THIS DRAWING IS PROTECTED BY COPYRIGHT AS AN UNPUBLISHED WORK.
 UNAUTHORIZED REPRODUCTION OF THIS DRAWING IS NOT PERMITTED.
 THIS DRAWING CONTAINS PROPRIETARY AND CONFIDENTIAL INFORMATION.
 This document is property of Nokia Corporation



Name	Reference schematic	Appr	dd-mmm-yy
Assoc		Des.	20-Sep-04
File		Dr.	16-Nov-07
Proj		Sheet	xx of yy
		Print	Yes
		V.	0.0
		Edit	14

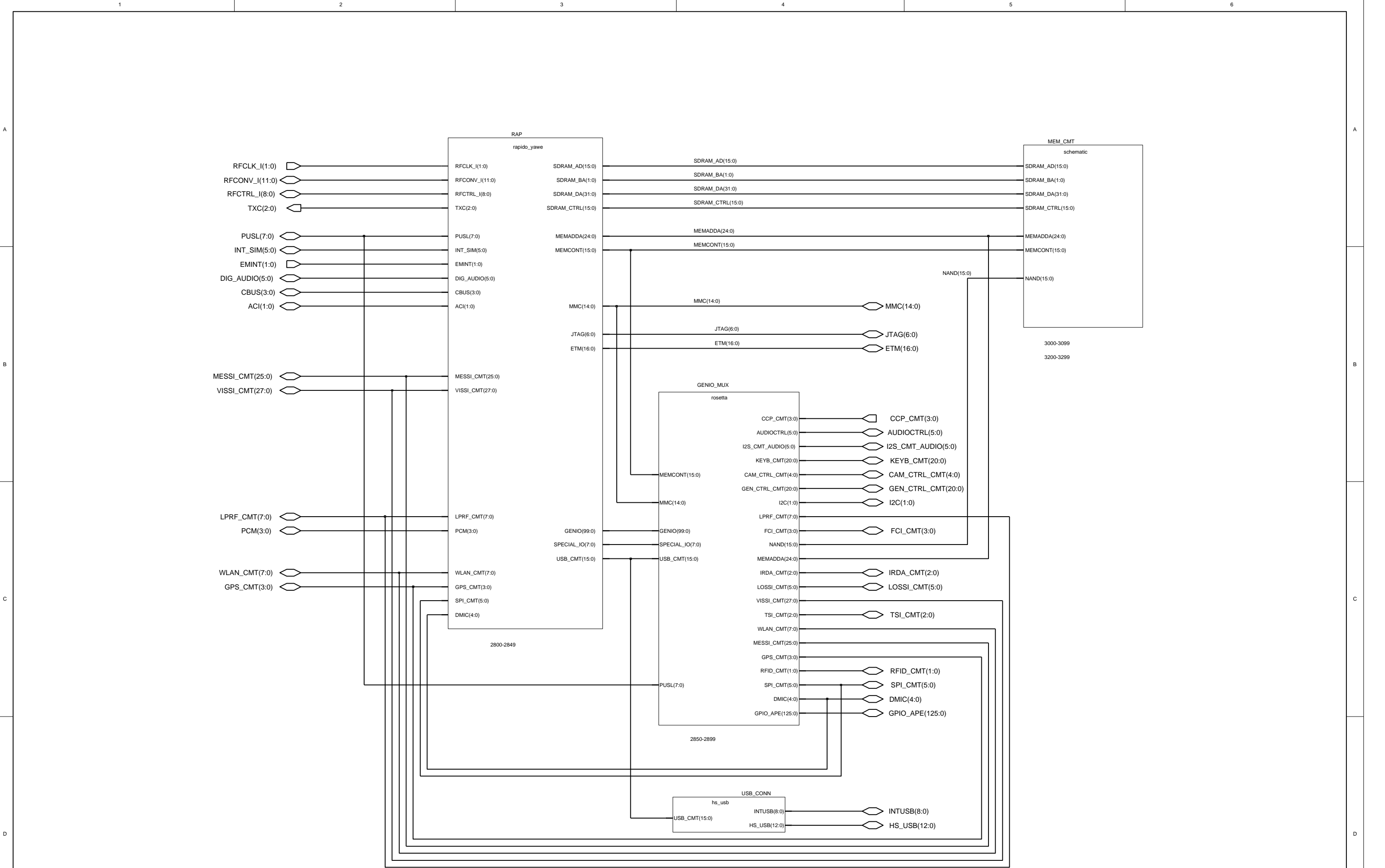

Copyright (C) Nokia Corporation. All rights reserved.
 THIS DRAWING IS PROTECTED BY COPYRIGHT AS AN UNPUBLISHED WORK.
 UNAUTHORIZED REPRODUCTION OF THIS DRAWING IS NOT PERMITTED.
 THIS DRAWING CONTAINS PROPRIETARY AND CONFIDENTIAL INFORMATION.
 This document is property of Nokia Corporation



Name		CMT SUBSYSTEM		Appr		dd-mmm-yy	
Assoc				Des.		22-Sep-03	
File				Dr.		04-Oct-07	
Proj				Sheet xx of yy		0 (01)	
		Print Yes		v. 0		Edit 7	

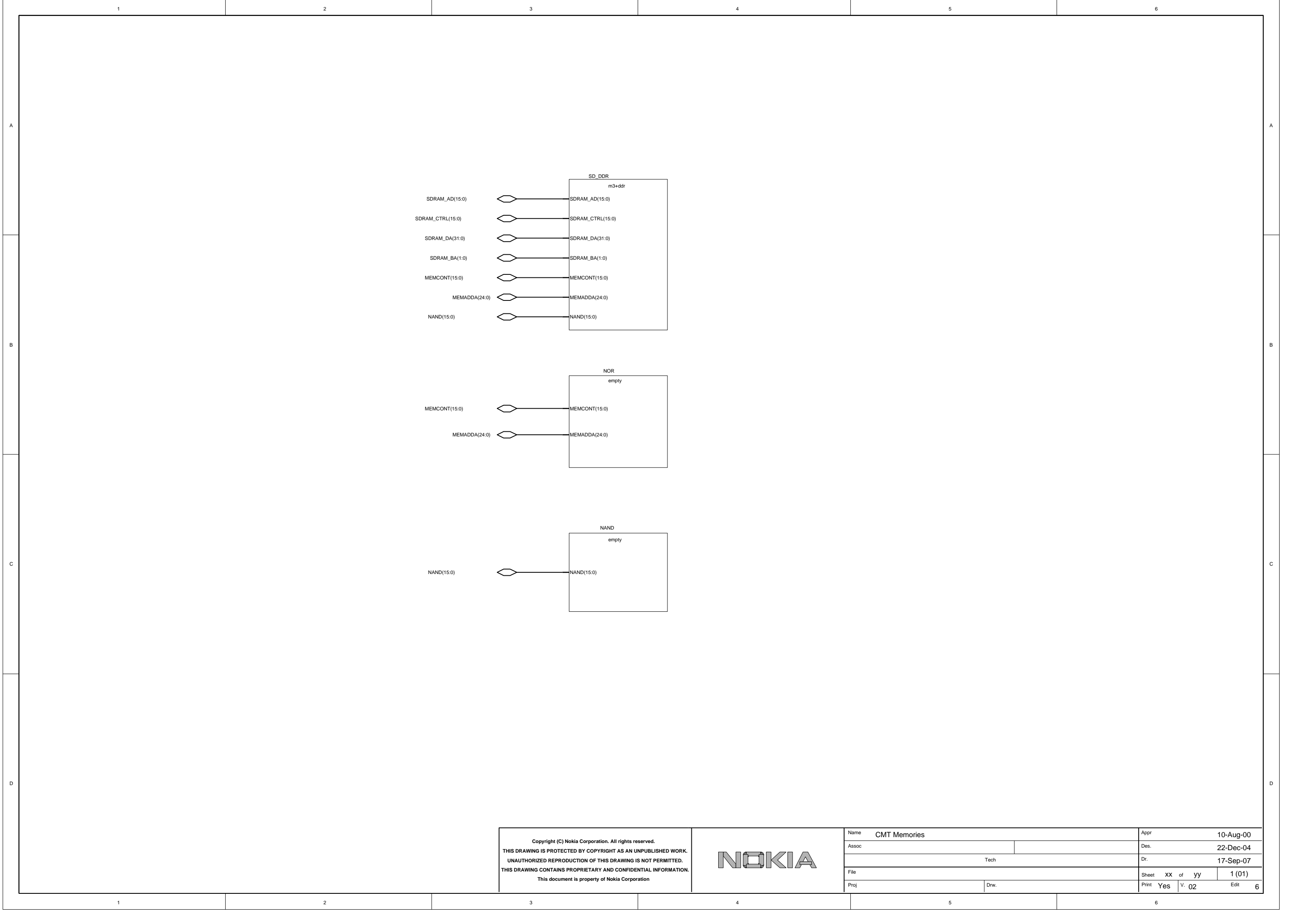

Copyright (C) Nokia Corporation. All rights reserved.
 THIS DRAWING IS PROTECTED BY COPYRIGHT AS AN UNPUBLISHED WORK.
 UNAUTHORIZED REPRODUCTION OF THIS DRAWING IS NOT PERMITTED.
 THIS DRAWING CONTAINS PROPRIETARY AND CONFIDENTIAL INFORMATION.
 This document is property of Nokia Corporation



Name	CMT Memories	Appr	10-Aug-00
Assoc		Des.	22-Dec-04
	Tech	Dr.	17-Sep-07
File		Sheet	xx of yy 1 (01)
Proj	Drw.	Print	Yes v. 02 Edit 6

A

B

C

D

A

B

C

D

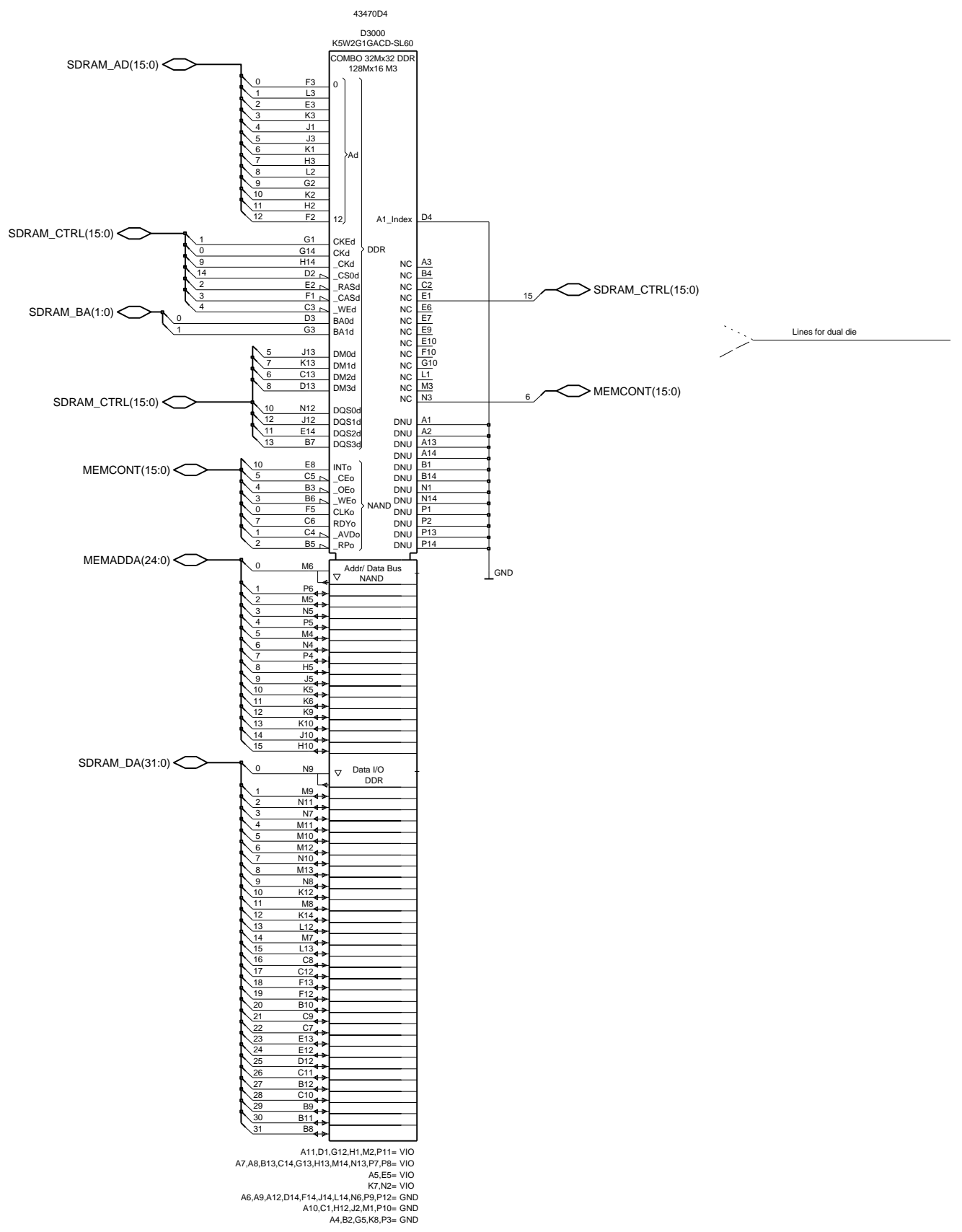
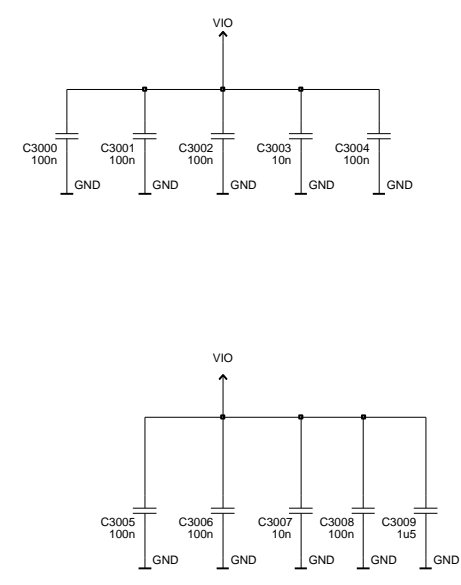

NAND(15:0)

Copyright (C) Nokia Corporation. All rights reserved. THIS DRAWING IS PROTECTED BY COPYRIGHT AS AN UNPUBLISHED WORK. UNAUTHORIZED REPRODUCTION OF THIS DRAWING IS NOT PERMITTED. THIS DRAWING CONTAINS PROPRIETARY AND CONFIDENTIAL INFORMATION. This document is property of Nokia Corporation		NOKIA		Name: Combo memory M3 16 1Gb + DDR 32 512Mb		Appr: dd-mmm-yy	
				Assoc:		Des: 22-Dec-04	
				File:		Dr: 05-Feb-08	
				Proj:		Sheet: xx of yy 0 (01)	
				Print: Yes		V: 0.0 Edit: 13	

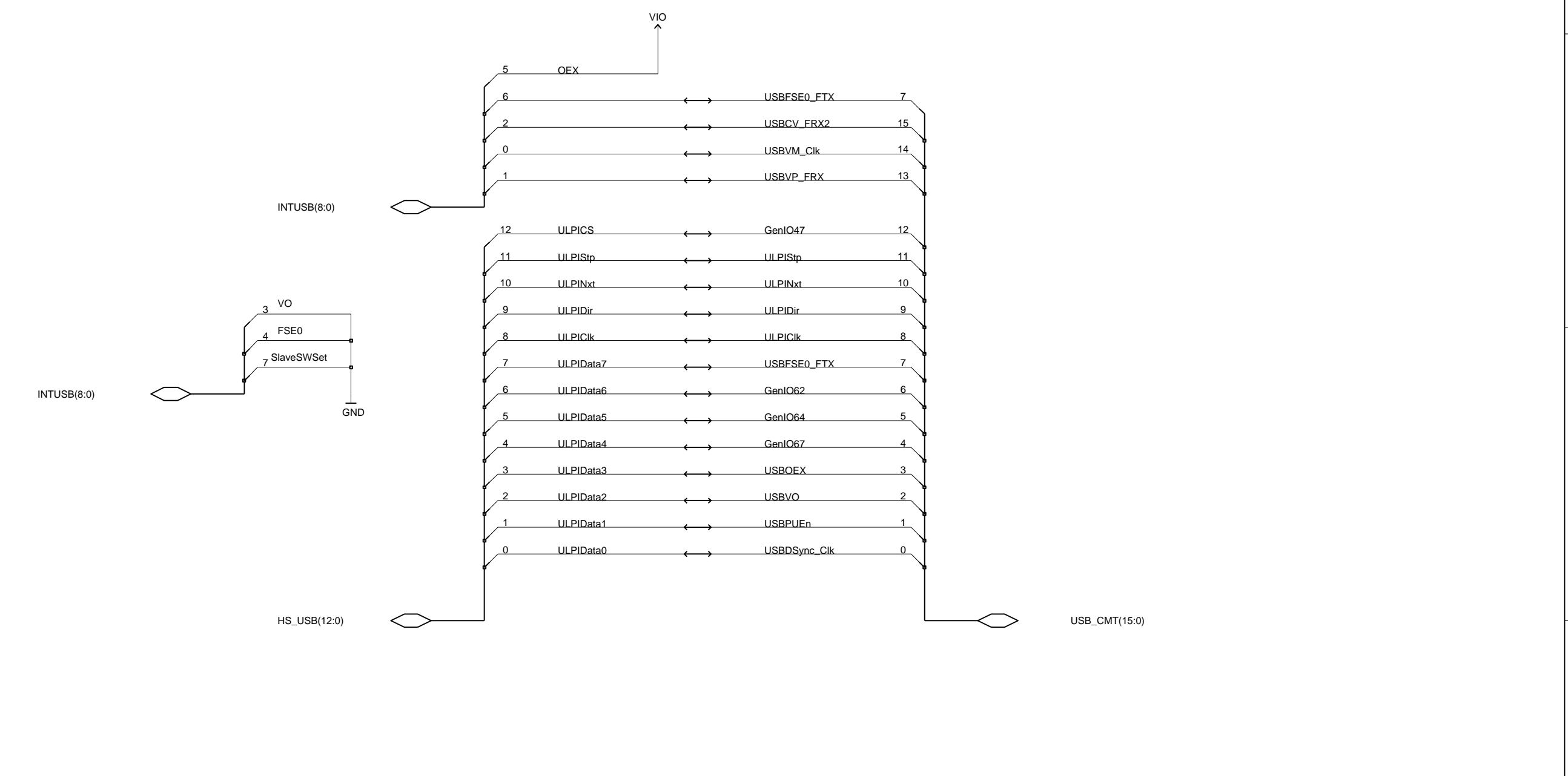

<p>Copyright (C) Nokia Corporation. All rights reserved. THIS DRAWING IS PROTECTED BY COPYRIGHT AS AN UNPUBLISHED WORK. UNAUTHORIZED REPRODUCTION OF THIS DRAWING IS NOT PERMITTED. THIS DRAWING CONTAINS PROPRIETARY AND CONFIDENTIAL INFORMATION. This document is property of Nokia Corporation</p>		Name HS USB		Appr	dd-mmm-yy	
		Assoc		Des.	04-Jun-03	
				Dr.	16-Nov-07	
		File		Sheet	XX of yy	0 (01)
		Proj		Drw.	Print Yes	V. 0.0 Edit 5

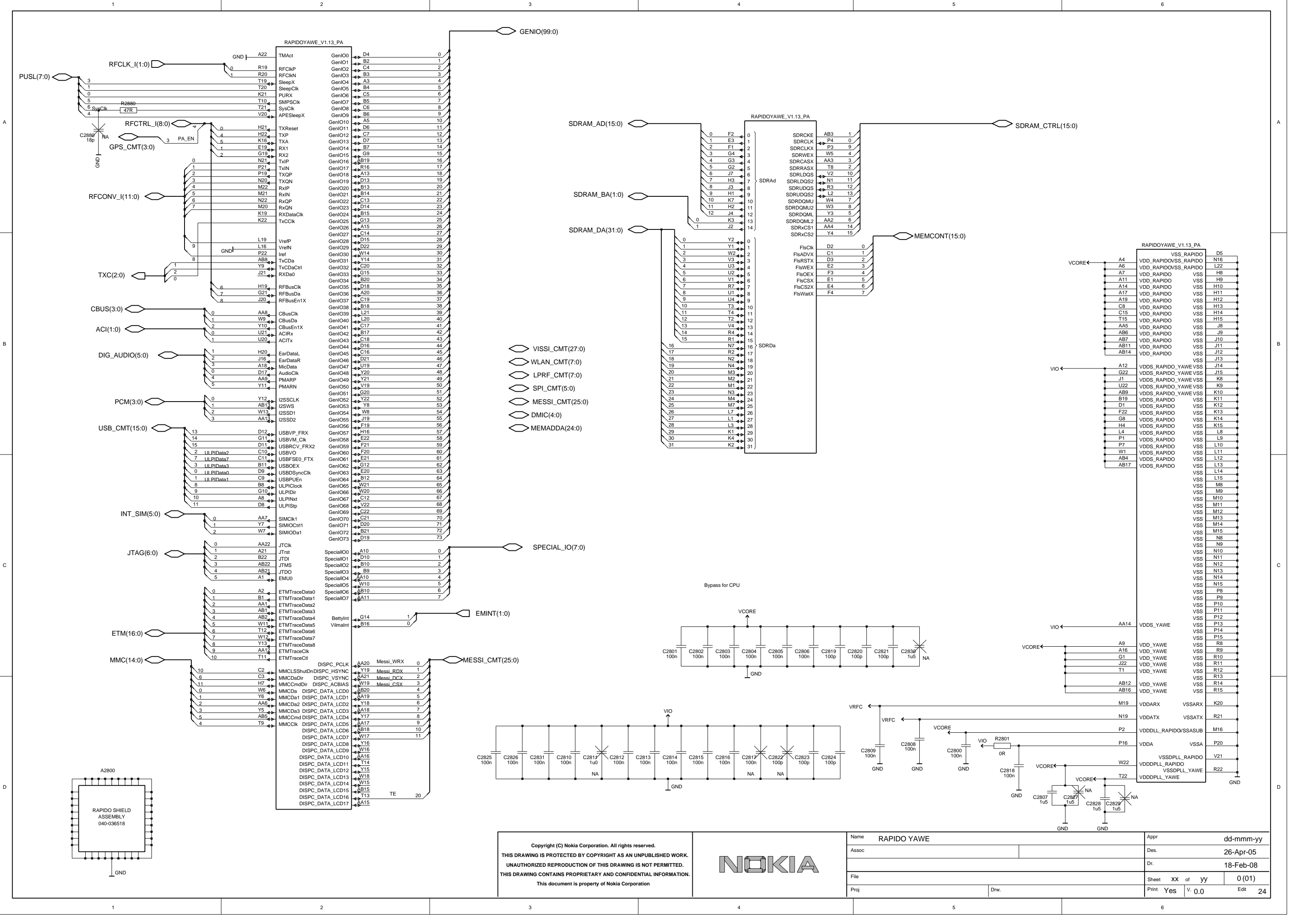

Copyright (C) Nokia Corporation. All rights reserved.
 THIS DRAWING IS PROTECTED BY COPYRIGHT AS AN UNPUBLISHED WORK.
 UNAUTHORIZED REPRODUCTION OF THIS DRAWING IS NOT PERMITTED.
 THIS DRAWING CONTAINS PROPRIETARY AND CONFIDENTIAL INFORMATION.
 This document is property of Nokia Corporation



Name	RAPIDO YAWE	Appr	dd-mmm-yy
Assoc		Des.	26-Apr-05
File		Dr.	18-Feb-08
Proj		Sheet	XX of yy
		Print	Yes
		V.	0.0
		Edt	24

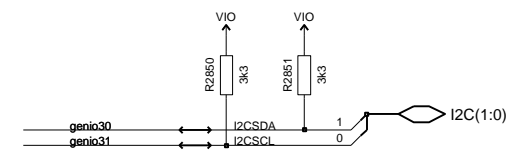
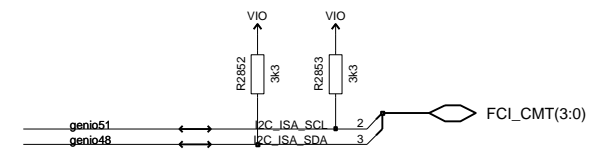
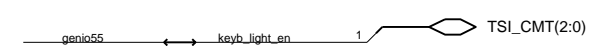
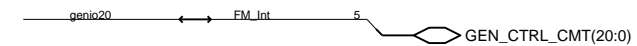
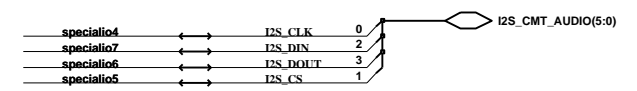
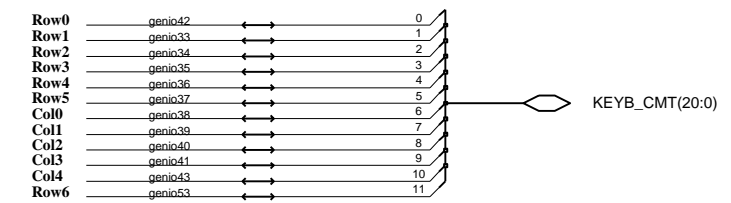
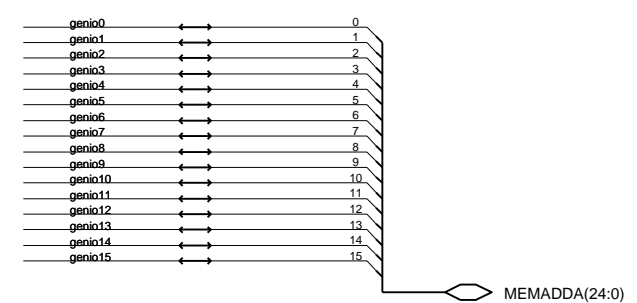
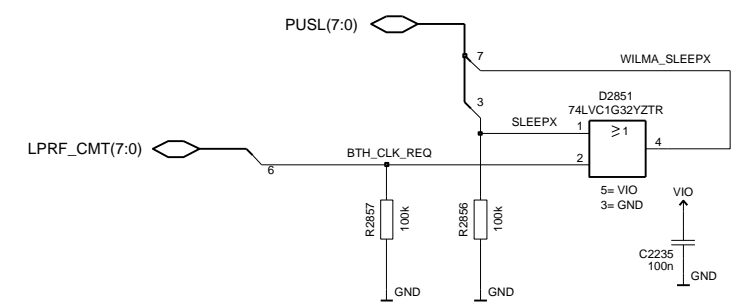
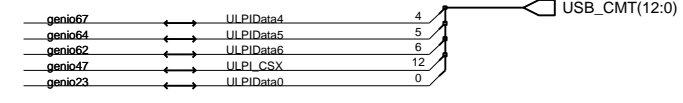
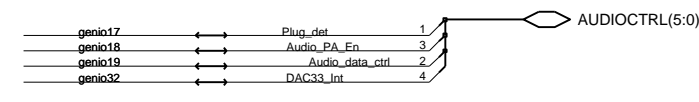
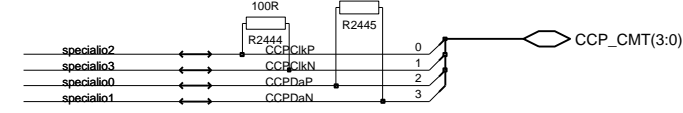
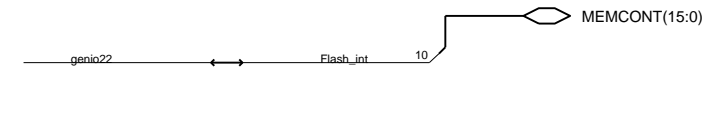
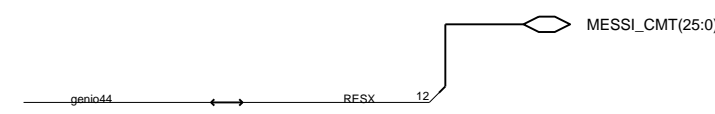
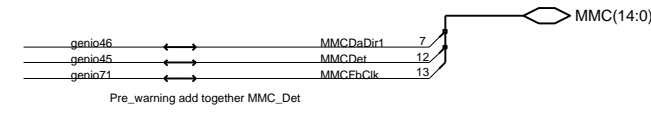
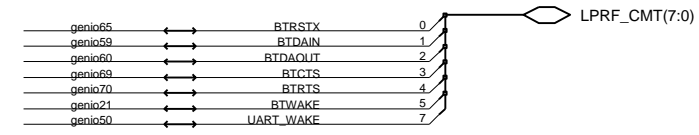
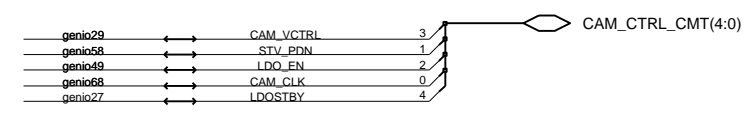
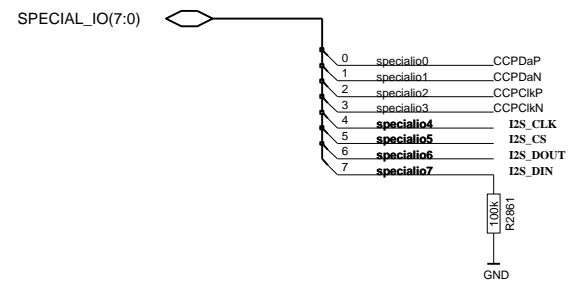
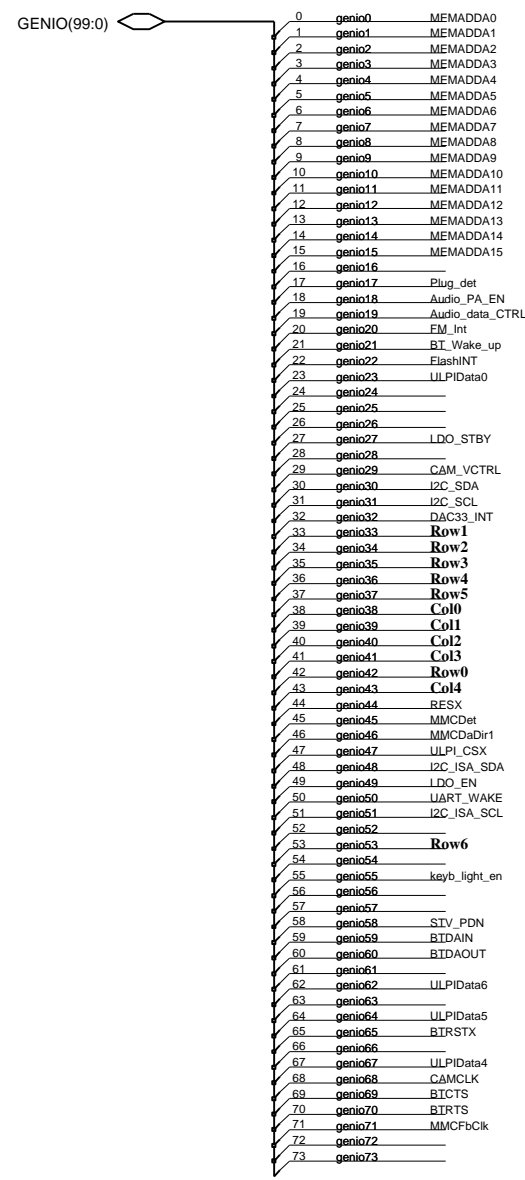

Copyright (C) Nokia Corporation. All rights reserved. THIS DRAWING IS PROTECTED BY COPYRIGHT AS AN UNPUBLISHED WORK. UNAUTHORIZED REPRODUCTION OF THIS DRAWING IS NOT PERMITTED. THIS DRAWING CONTAINS PROPRIETARY AND CONFIDENTIAL INFORMATION. This document is property of Nokia Corporation		NOKIA		Name: Genio mux		Appr: dd-mmm-yy	
				Assoc:		Des: 23-Feb-06	
				File:		Dr: 13-Mar-08	
				Proj:		Sheet XX of yy: 0 (01)	
				Draw:		Print Yes V. 0.0 Edit 26	

CBB5X

TOP SHEET

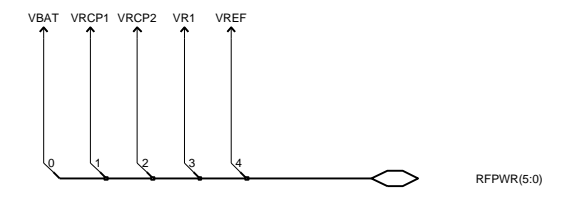
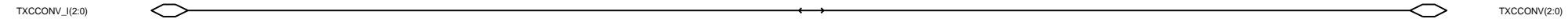
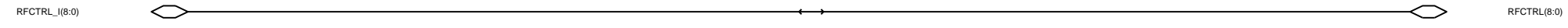
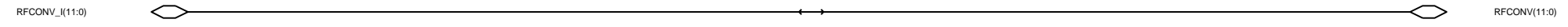
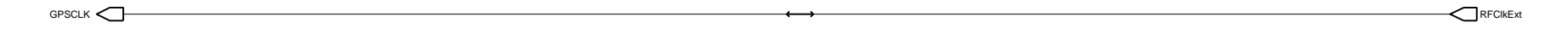
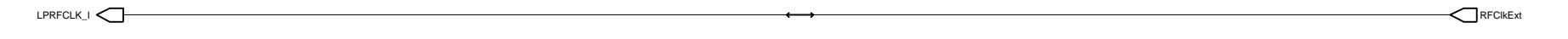
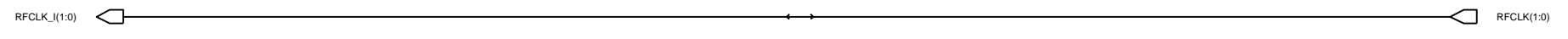

Copyright (C) Nokia Corporation. All rights reserved.
 THIS DRAWING IS PROTECTED BY COPYRIGHT AS AN UNPUBLISHED WORK.
 UNAUTHORIZED REPRODUCTION OF THIS DRAWING IS NOT PERMITTED.
 THIS DRAWING CONTAINS PROPRIETARY AND CONFIDENTIAL INFORMATION.
 This document is property of Nokia Corporation



Name	RF IF	Appr	dd-mmm-yy
Assoc		Des.	15-Jan-03
File		Dr.	12-Sep-07
Proj		Sheet xx of yy	0 (01)
	Draw.	Print Yes v. 0	Edit 2



